

Model PA2204A
Load Cell Combiner Module
Instruction Manual

AMALGAMATED INSTRUMENT CO PTY LTD

ACN: 001 589 439

*Unit 5, 28 Leighton Place Hornsby
NSW 2077 Australia*

*Telephone: +61 2 9476 2244
Facsimile: +61 2 9476 2902*

*e-mail: sales@aicpl.com.au
Internet: www.aicpl.com.au*

Table of Contents

1	Introduction	3
2	Mechanical details	3
3	Electrical connections	4
4	Balancing the load cells	5

1 Introduction

The load cell combiner is used to equalise the mV/V output of two, three or four load cells allowing them to be balanced and combined at the output. The combiner circuit board contains four input connectors and one output connector, each connector is of the screw terminal type.

There is also a variable resistor for each channel. These variable resistors allow for the individual adjustment of the excitation voltage, and hence the mV output, for each cell to be passed on to the output.

2 Mechanical details

Case material: Stainless steel. Dimensions are in mm. Weight = 560 gms. Case rating IP65. Mounting screws not provided.

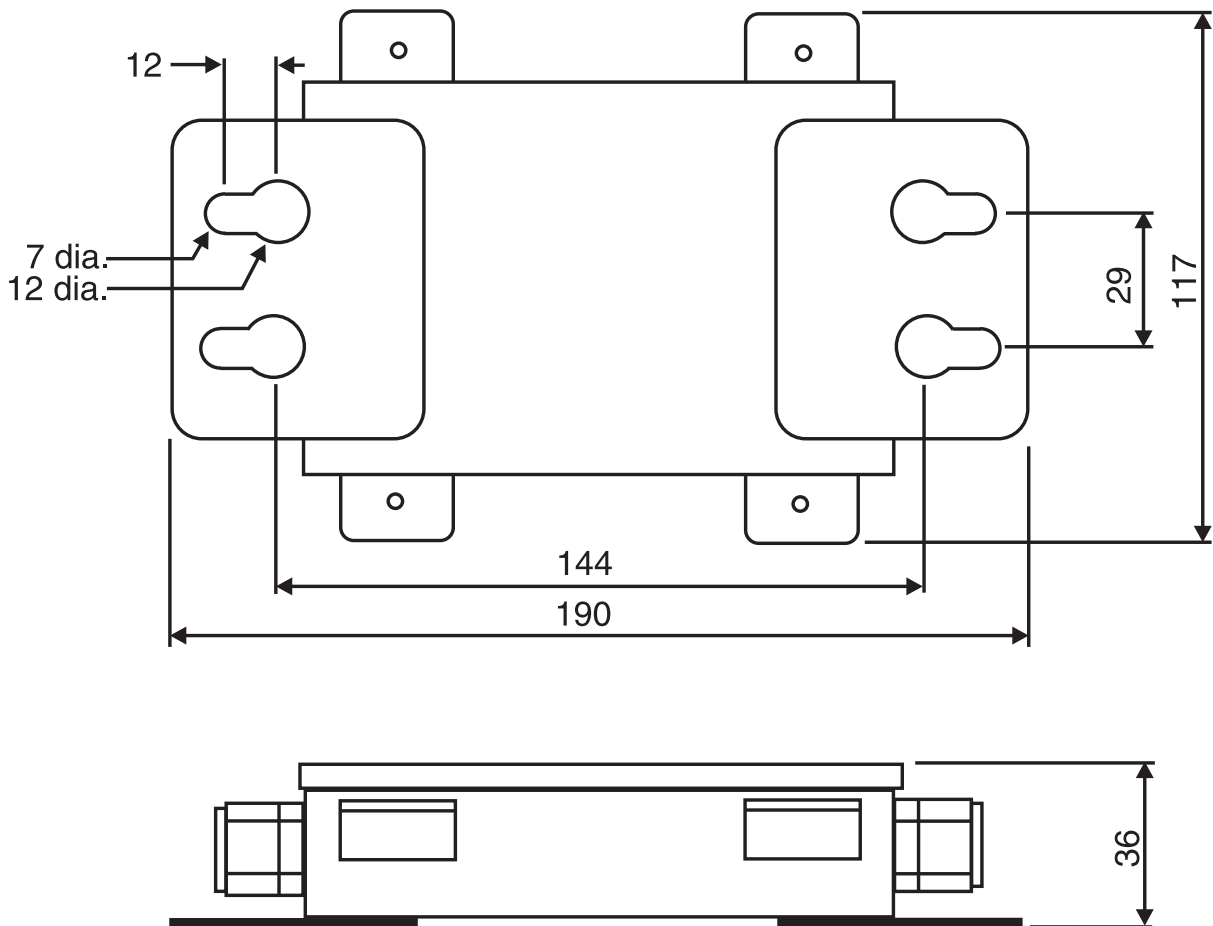

3 Electrical connections

Connections terminals are provided for up to 4 individual load cells plus connections for the load cell amplifier/display. The excitation voltage is provided by the load cell amplifier/display. Maximum wire size 2.5mm dia.

View with lid removed and 4 load cell connected

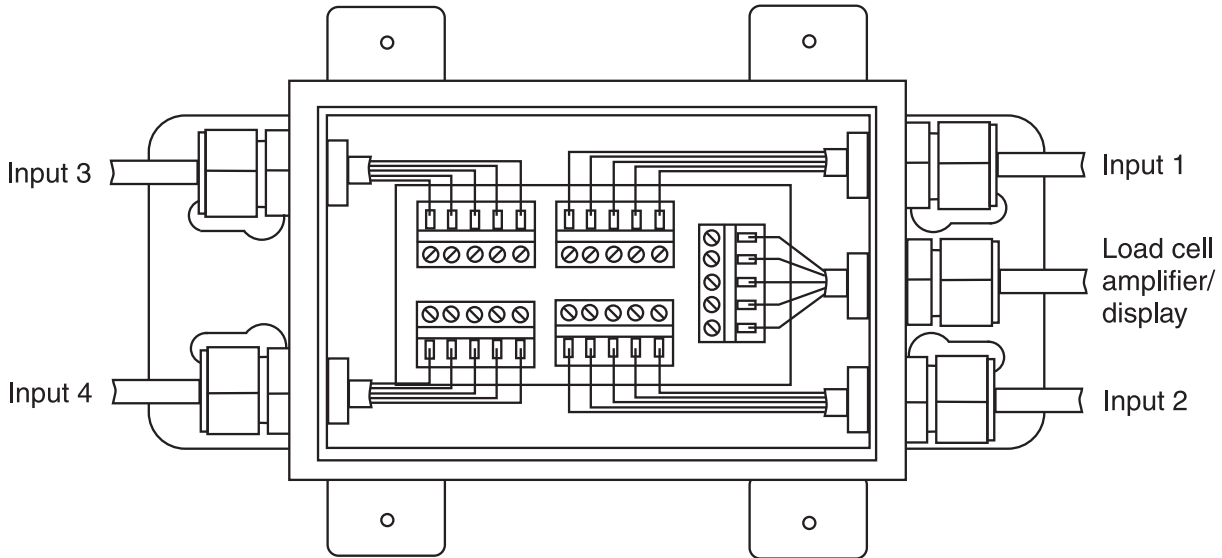

Connections exploded view

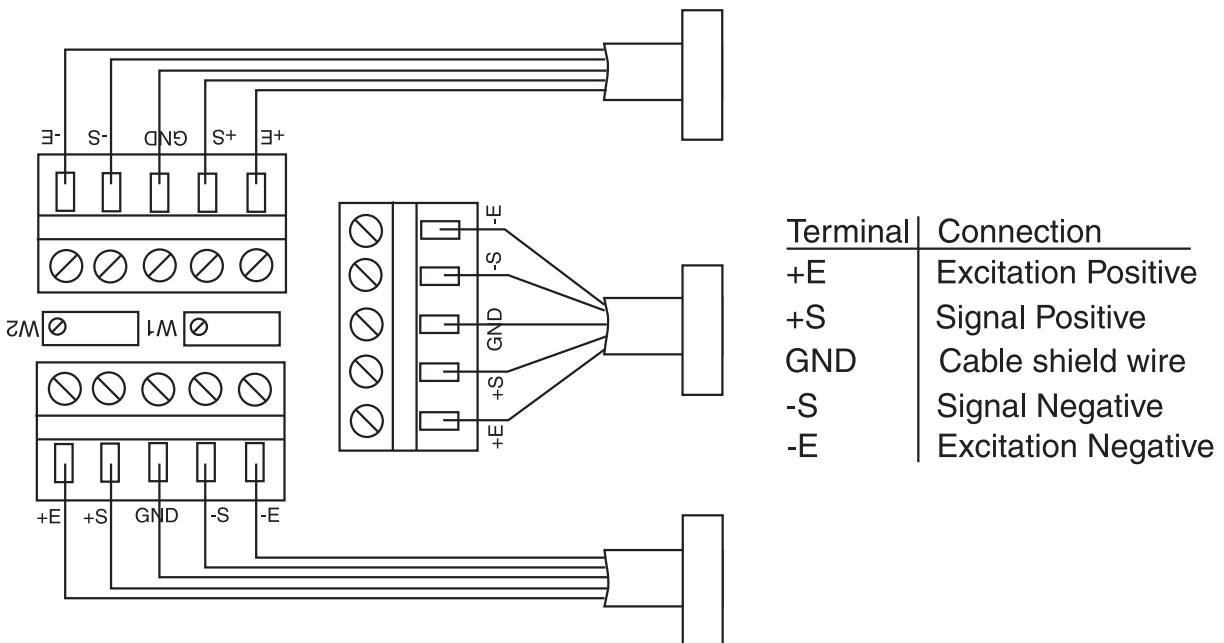

4 Balancing the load cells

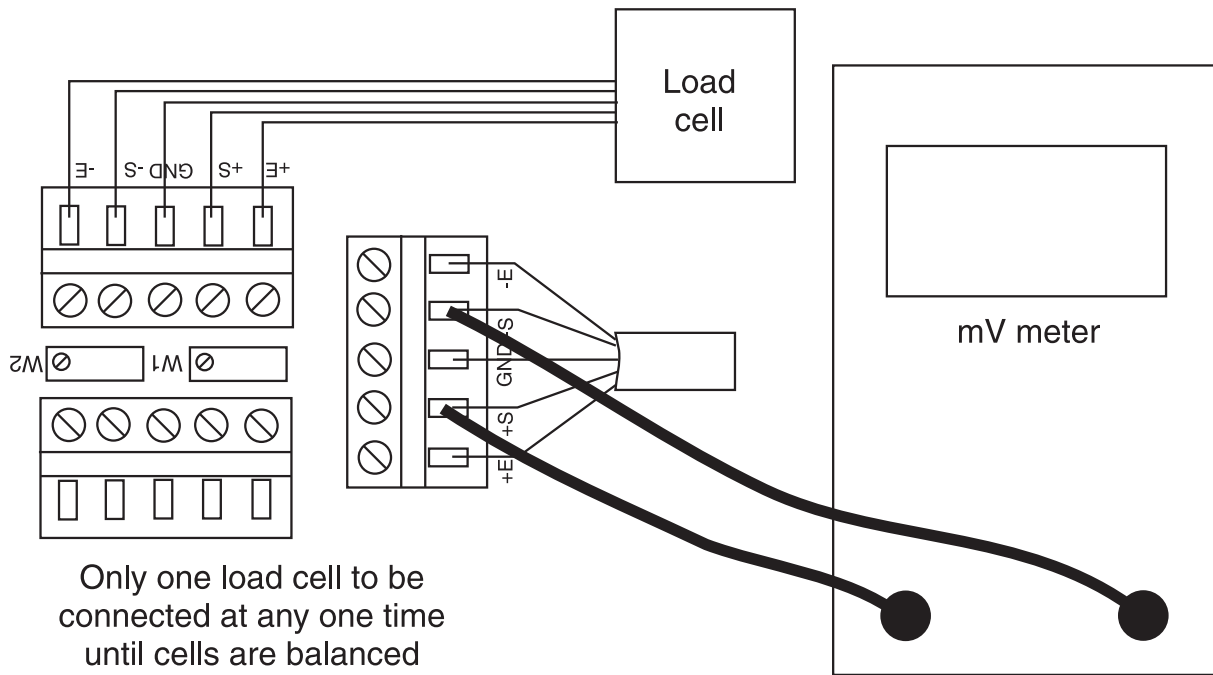

The load cells are connected individually and the cell with the lowest mV output is used as the reference input and the other cells are balanced to match the reference. Variable resistors are provided for this adjustment with variable resistor W1 being used for input 1, W2 for input 2 etc.

The setup procedure is listed below:

1. Connect the wires for the load cell amplifier/display and ensure that excitation is present across +E and -E terminals. Place a mV meter across the +S and -S terminals.
2. Connect the input 1 load cell to the combiner input 1 terminals and place a known load on the cell. The load should be as high as practicable but within the capacity of the cell. A zero load adjustment is not suitable for setup. If the cells are connected to a platform place the load in the middle of the platform.
3. Measure and note the output mV signal due to input 1 only. A table is provided at the end of this section for if you wish to keep a record of these measurements.
4. Disconnect all input 1 wires and connect the input 2 load cell to the combiner input 2 terminals and place the same known load as used on input 1 on the cell.
5. Measure and note the output mV signal due to input 2 only.
6. Repeat the process for the remaining inputs if more than 2 inputs are to be connected. It is essential that only one load cell is connected at any one time until the outputs are balanced.
7. Connect only the cell with the highest recorded output and adjust its variable resistor until its mV output matches that of the lowest output then disconnect this cell.
8. Repeat step 7 above for the remaining inputs. Ensuring that only one load cell is connected at any one time until the outputs are balanced.
9. When all inputs have been balanced all of the cells can be wired into the combiner ready for operation.

Record your mV readings below.

Input	mV reading
Input 1	
Input 2	
Input 3	
Input 4	