

**Model LD-WT**  
**Large Digit Display/Controller**  
**Operation and Instruction Manual**

---

*AMALGAMATED INSTRUMENT CO*

*Unit 5, 28 Leighton Place Hornsby  
NSW 2077 Australia*

*Telephone: +61 2 9476 2244*

*Facsimile: +61 2 9476 2902*

*ABN: 80 619 963 692*

*e-mail: sales@aicpl.com.au*

*Internet: www.aicpl.com.au*

# Table of Contents

<b>1</b>	<b>Introduction</b>	<b>3</b>
<b>2</b>	<b>Mechanical installation</b>	<b>4</b>
<b>3</b>	<b>Electrical installation</b>	<b>6</b>
<b>4</b>	<b>Function tables - summary of setup functions</b>	<b>11</b>
<b>5</b>	<b>Explanation of functions</b>	<b>15</b>
<b>6</b>	<b>Calibration</b>	<b>38</b>
<b>7</b>	<b>Batching operation</b>	<b>42</b>
<b>8</b>	<b>Serial communication</b>	<b>44</b>
<b>9</b>	<b>Serial operation</b>	<b>46</b>
<b>10</b>	<b>Modbus operation</b>	<b>50</b>
<b>11</b>	<b>Data logger</b>	<b>52</b>
<b>12</b>	<b>Specifications</b>	<b>55</b>
<b>13</b>	<b>Guarantee and service</b>	<b>57</b>

# 1 Introduction

## General description

This manual contains information for the installation and operation of the LD-WT Monitor. The LD-WT is a high speed/precision load cell/strain gauge monitor which may be configured to accept an input from any conventional 4 or 6 wire strain gauge bridge of 80 $\Omega$  or higher. The instrument has a full scale range of 0.5mV/V to 100mV/V. Excitation voltages of 5 Volt, 10V or 15 Volt are selectable by PCB links. The LD is suitable for measuring weight, pressure, force, torque and similar variables. Calibration, setpoint and other set up functions are easily achieved by push buttons (located on the front panel). A choice of calibration methods is given to suit different calibration requirements.

Four standard inbuilt relays provide alarm on/off control functions. Auto zero and batch functions are included and may be set as required. Serial communications (RS232 or RS485) and dual channel 4–20mA analog retransmission are optionally available. Inbuilt data logger chips of 32k or 128k are also optionally available. A standard non isolated RS232 serial port is provided, this port is dedicated for use with special Windows PC software which can be used to log and view live data. The standard port and Windows software can also be used with the optional data logger. The standard port is disabled if the optional serial port is fitted.

An inbuilt totaliser memory allows remote inputs or the **P** button to be used to add display values to the memory and display the total. A remote input can be used to clear the total.

Unless otherwise specified at the time of order, your LD display has been factory set to a standard configuration. The configuration and calibration is easily changed by the user. Initial changes may require dismantling the instrument to alter PCB links, other changes are made by push button functions.

LED models have an inbuilt light sensor which can be used to automatically alter the display brightness to suit ambient light conditions e.g. to avoid glare when in a dark environment.

## Output options

- Isolated dual channel analog retransmission configurable for 4–20mA.
- Isolated RS485 or RS232 serial communications (ASCII or Modbus RTU).
- Internal datalogger memory with either 32k or 128k memory, note this option requires that a serial communications option is also fitted.

## 2 Mechanical installation

### 2.1 20mm, 38mm, 45mm, 57mm and 58mm LED

An optional panel mount kit is available for these size displays. Panel cut out size is 240 x 130mm (-0.0mm / +0.5mm). Weight: All types 1.6kg approx.

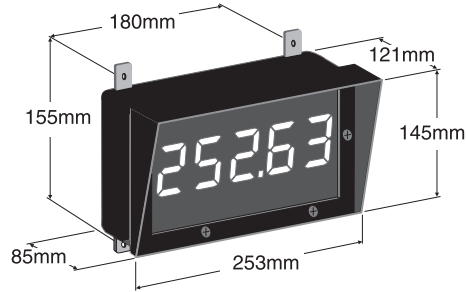

### 2.2 100mm 4 digit LED

Weight 10kg (LED)

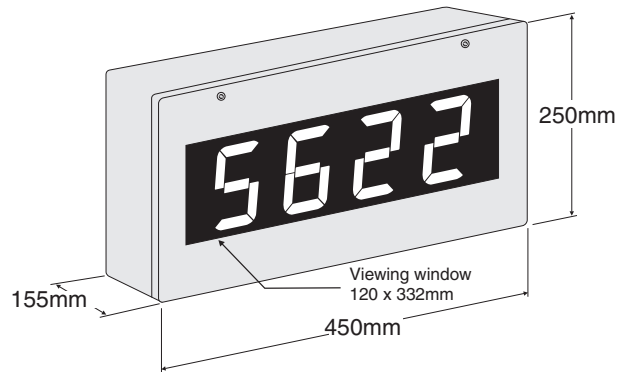

### 2.3 100mm 6 digit LED

Weight 14kg (LED)

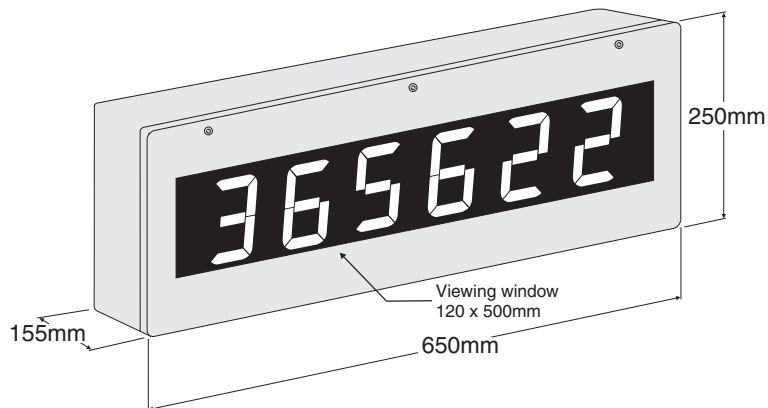

## 2.4 200mm 4 digit LED

Weight 14kg.

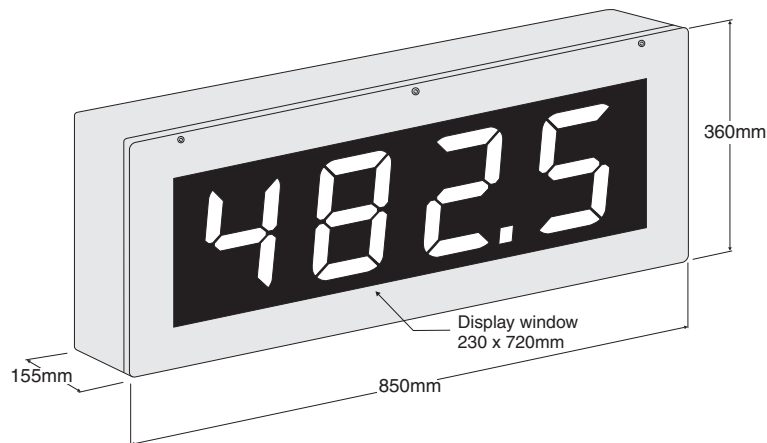

## 2.5 Cable entry and Mounting brackets

For 20 to 58mm displays no holes are pre drilled. For all 100mm and 200mm displays 3 off 20mm holes are drilled at the bottom of the case, these are fitted with 2 x IP65 grommets and 1 x air vent which allows moisture to exit the case but not enter. Four mounting brackets and four blind grommets are supplied for use with all metal case large digit displays. Diagrams below illustrate vertical and horizontal installation for mounting brackets. If mounting without the brackets is preferred then the 9mm dia. case holes provided for the brackets can be used as alternative mounting holes. Any rear holes not used for mounting should be sealed.

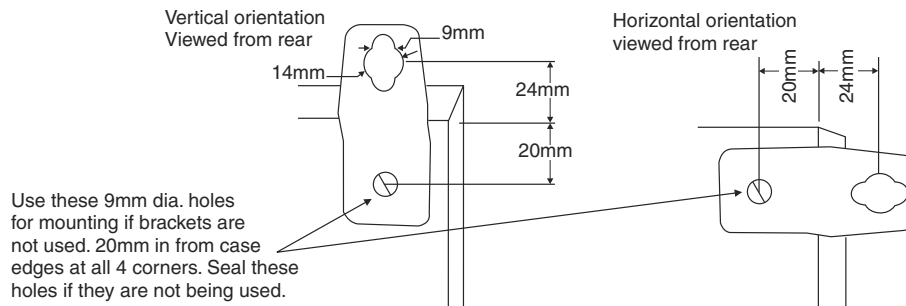

### 3 Electrical installation

#### 3.1 Electrical installation

The LD instrument is designed for continuous operation and no power switch is fitted to the unit. It is recommended that an external switch and fuse be provided to allow the unit to be removed for servicing. The terminal blocks are plug in screw type for ease of installation and allow for wires of up to 1.5mm<sup>2</sup> (2.5mm<sup>2</sup> for relay, AC or isolated DC supply connections) to be fitted. Connect the wires to the appropriate terminals as indicated below. Refer to other details provided in this manual to confirm proper selection of voltage, polarity and input type before applying power to the instrument. When power is applied the instrument will cycle through a display sequence, indicating the software version and other status information.

#### 3.2 Main circuit board layout

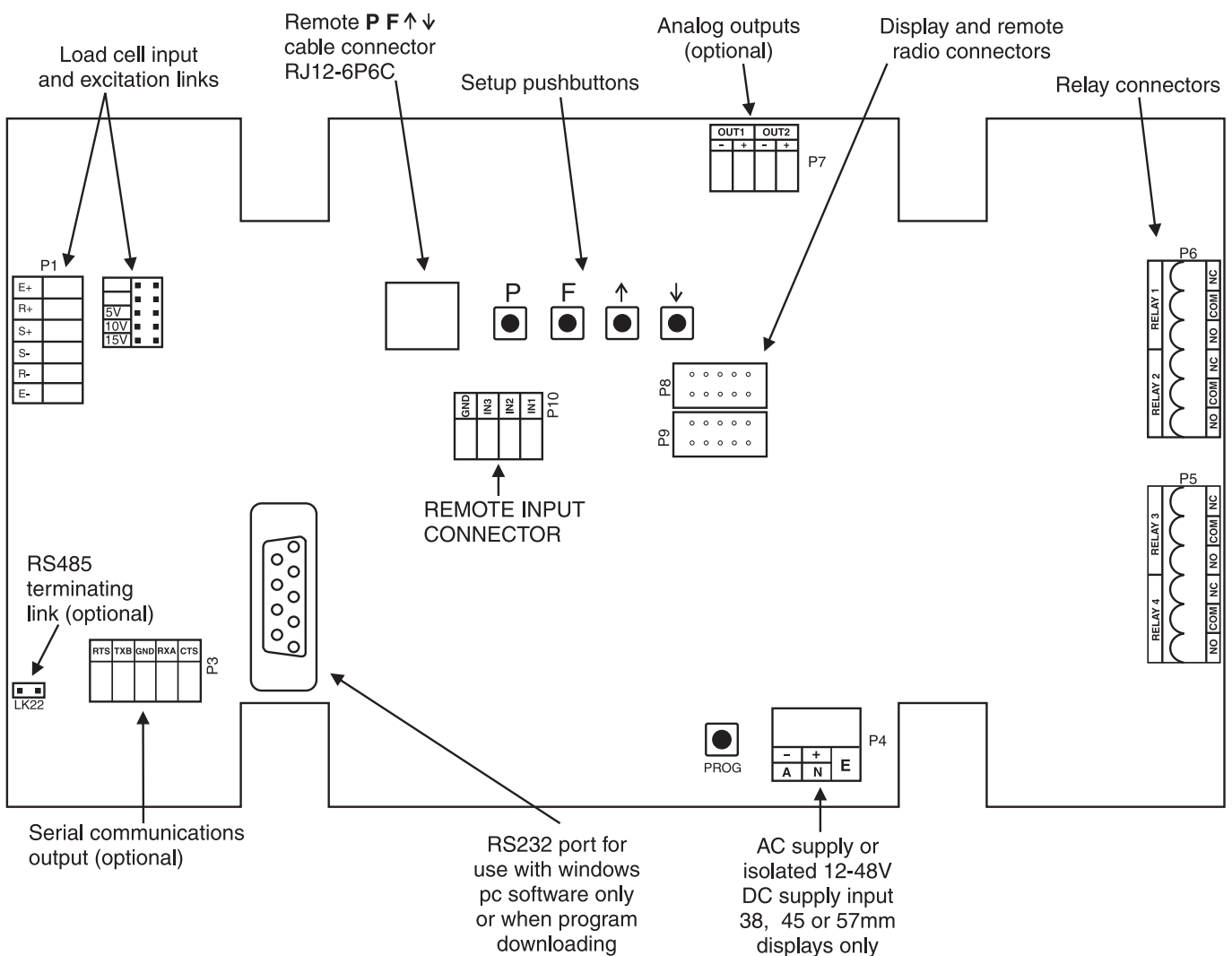

#### 3.3 38mm LED, 45mm LED or 57mm LED display power supplies

AC power connections use a plug in connector with screw terminals at P4 (2.5mm<sup>2</sup> max. wire). Isolated DC supplies (12-48VDC) use the same terminals. Note supply type is factory configured.

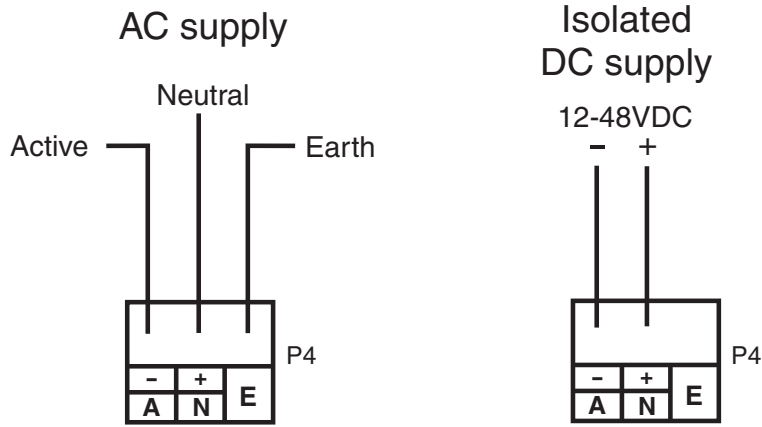

### 3.4 100mm, 200mm LED and 100mm electromagnetic display power supplies

Isolated DC supplies (12 to 24VDC) connect to the isolated supply pcb on the base board. AC supplies connect to the transformer primary on the base board. The base board is located under the input circuit board, see wiring diagram for AC supplies on the next page.

#### Optional isolated DC supply

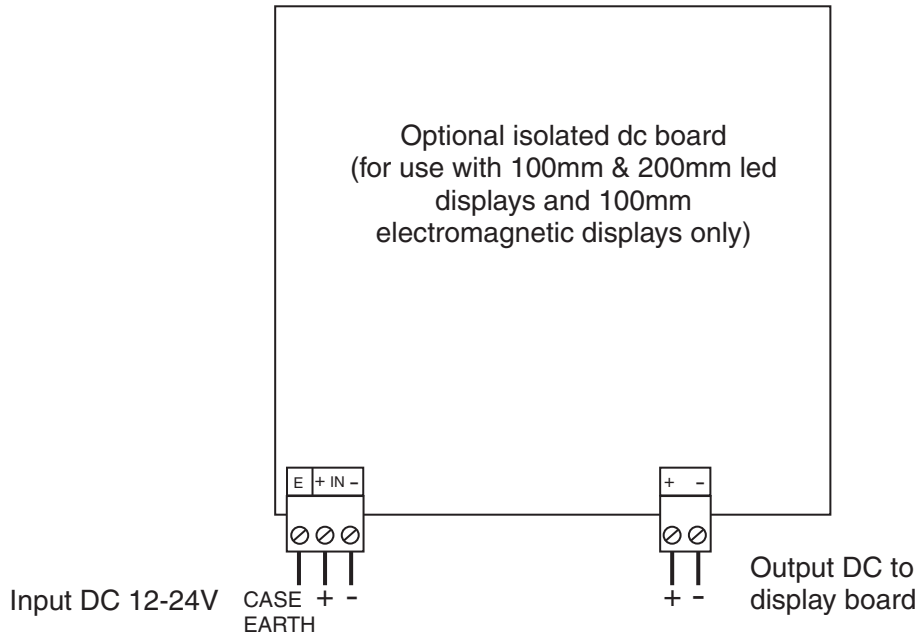

240 & 110VAC supplies.  
For 100mm/200mm LED or 100mm  
electromagnetic display types only.

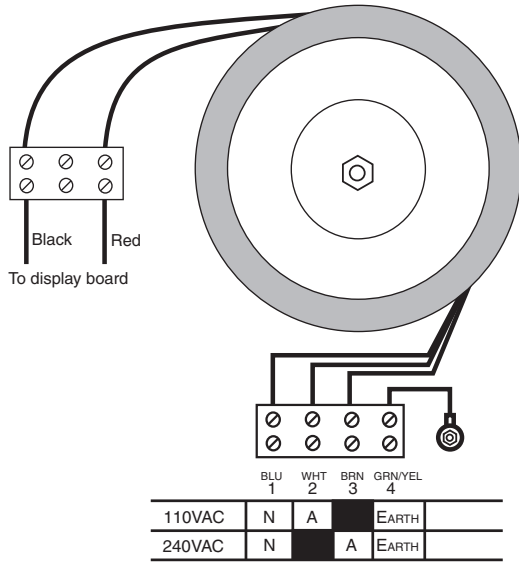

Low voltage AC supplies.  
For 100mm/200mm LED or 100mm  
electromagnetic display types only.

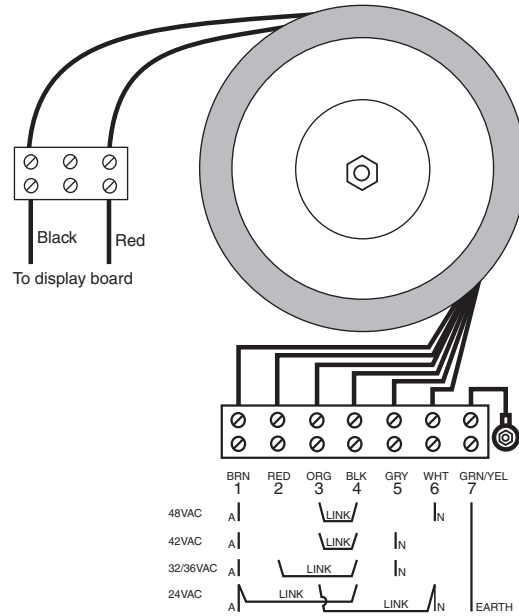

### Wiring examples 240VAC & 110VAC

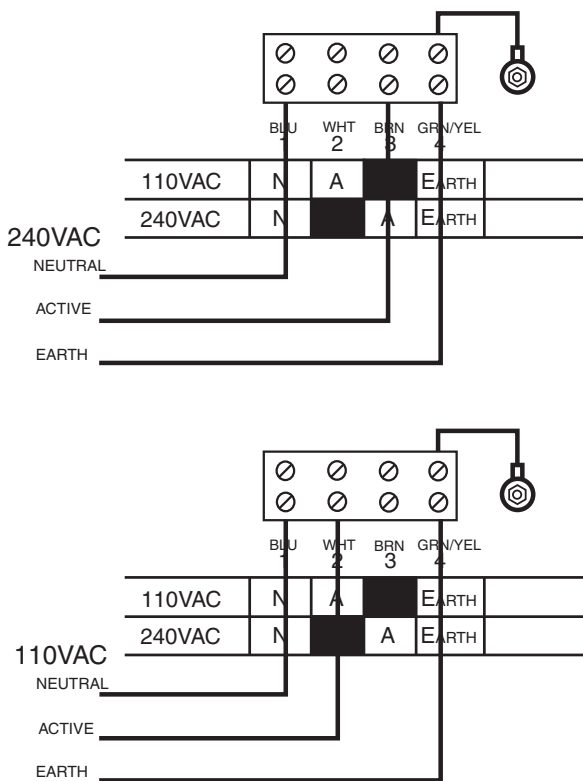

### Wiring examples low voltage AC

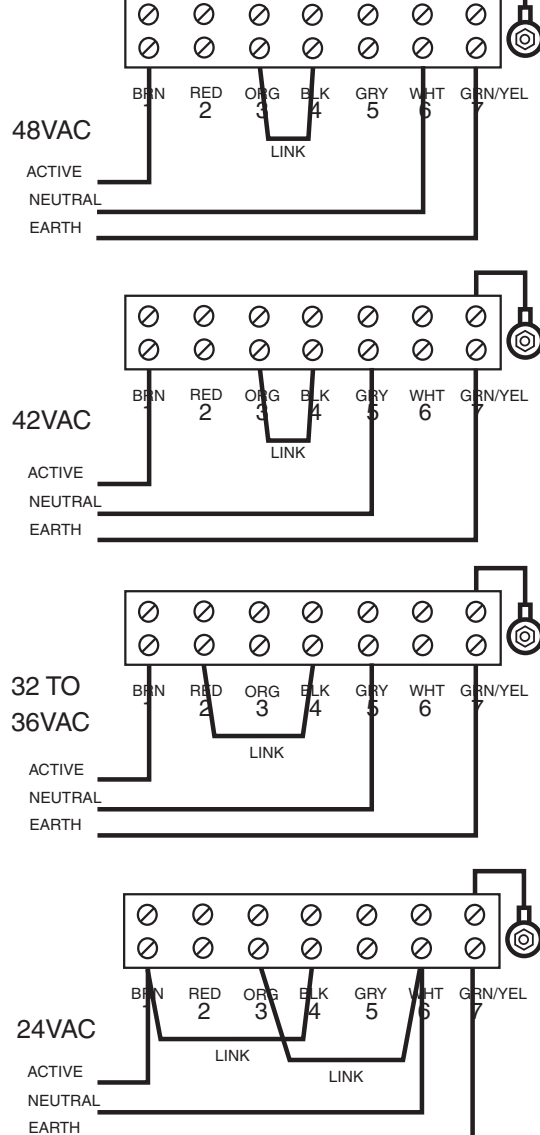

Important note: the 240V & 110V supplies use the same transformer, low voltage instruments use a different transformer. Do not use a low voltage transformer for 240V or 110V or vice versa.



### 3.5 Input connections

4 wire load cell/pressure sensor connection - note links required as shown

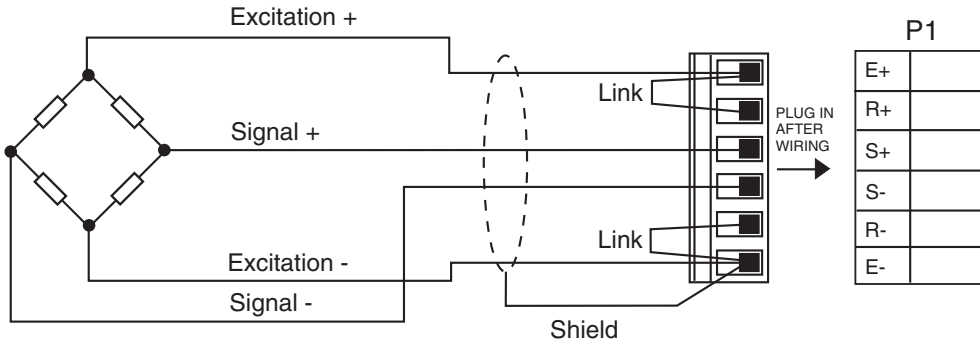

6 wire load cell/pressure sensor connection

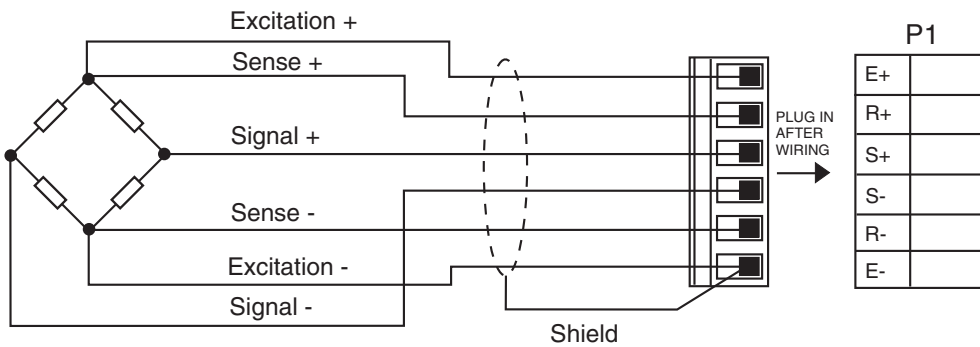

### 3.6 Relay connections

The LD is supplied with four alarm relays as standard with connections on terminals P5 and P6. The relays are changeover types and are rated at 5A, 240VAC into a resistive load. The relay contacts are voltage free and may be programmed for normally open or normally closed operation. With power removed the relay contacts will be in the normally closed position i.e. shorting between NC and COM.

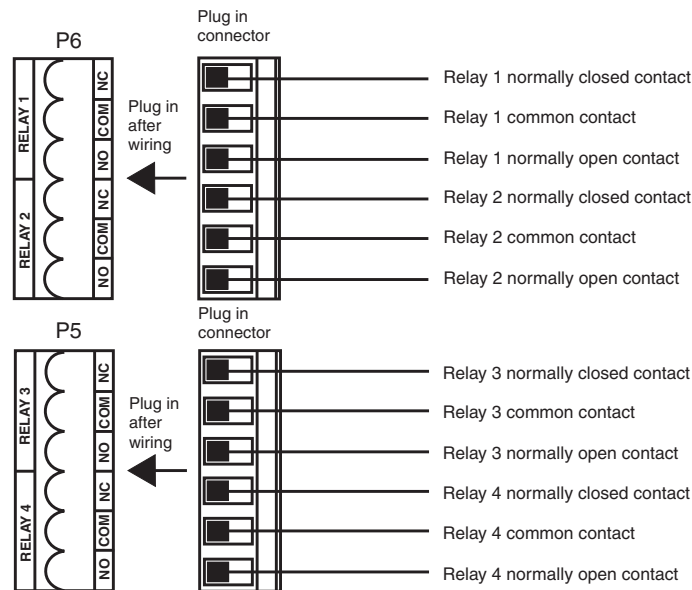

### 3.7 Excitation voltage links

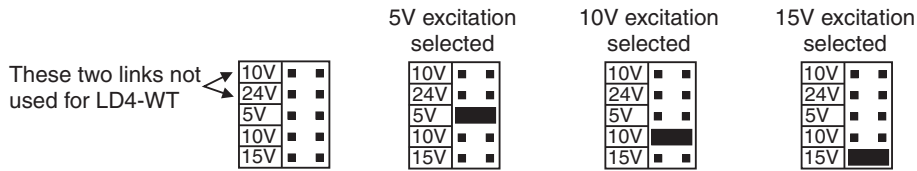

### 3.8 Optional analog output connections

There are two channels of optional analog outputs. Each output can be individually scaled and is current sourcing i.e. voltage to drive the 4–20mA outputs is provided internally. The outputs should not be connected to another current sourcing device i.e. should not be connected to an external loop supply. The connection diagram below shows connection to passive (current sinking) inputs.

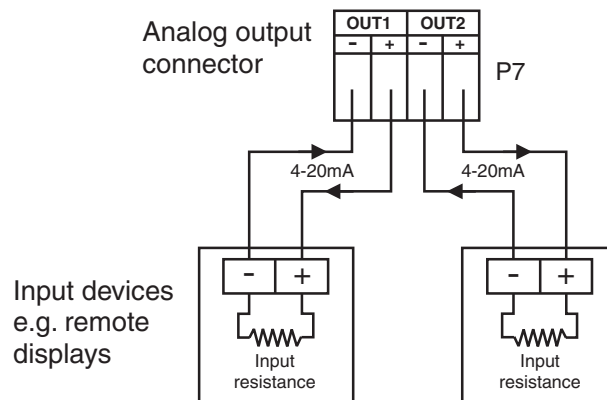

### 3.9 Standard serial communications connections

Plug in connector  
9 pin male "D" type,  
rear terminals shown

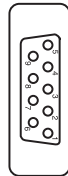
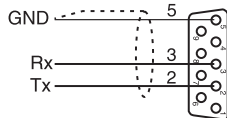

RS232 port for use in **R.buS** mode with Windows PC software purchased for use with this instrument or for on site software update only. This port will be disabled if the optional serial communications port fitted. If this port is to be used for **R.buS** communication the **SEF. TYPE** and **SEF. TYPE** functions must be set to **NONE**

Note: when connecting using Rs232 the Tx line at the display connects to the Rx line at the device it is communicating with. Likewise the Rx line at the display connects to Tx

### 3.10 Remote input and remote keypad (cable version) connector

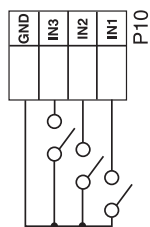

REMOTE INPUT CONNECTOR

IN1, IN2 and IN3 are the remote input switches.  
F.1 **FP** is used to set the IN1 switch function.  
F.1 **FN2** is used to set the IN2 switch function.  
F.1 **FN3** is used to set the IN3 switch function.  
Latching or momentary switches can be used depending on the function selected.

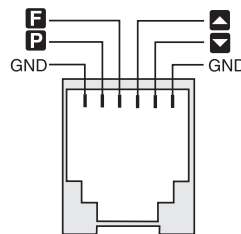

Remote keypad connector

Optional serial output connections - see Chapter 8

## 4 Function tables - summary of setup functions

Note: the order in which the functions appear on the display may not be exactly as shown below. The availability and order of functions is determined by choice of function settings and options fitted.

Functions in this first table are available in **FUNC** or **CAL** mode

Display	Function	Range	Default	Your record	Ref/Page
<b>RxLo</b>	Low setpoint value for designated alarm relay <i>x</i>	Any display value or <b>OFF</b>	<b>OFF</b>	See 4.1	5.1 / 16
<b>RxHi</b>	High setpoint value for designated alarm relay <i>x</i>	Any display value or <b>OFF</b>	<b>OFF</b>	See 4.1	5.2 / 16
<b>RxHY</b>	Hysteresis value for the designated alarm relay <i>x</i> .	<b>0</b> to <b>9999</b>	<b>10</b>	See 4.1	5.3 / 17
<b>Rxtt</b>	Trip time delay for the designated alarm relay <i>x</i> .	<b>0.0</b> to <b>999.9</b>	<b>0.0</b>	See 4.1	5.4 / 17
<b>Rxrt</b>	Reset time delay for the designated alarm relay <i>x</i> .	<b>0.0</b> to <b>999.9</b>	<b>0.0</b>	See 4.1	5.5 / 17
<b>Rxn.o</b> or <b>Rxn.c</b>	Alarm relay <i>x</i> action to normally open or normally closed	<b>Rxn.o</b> or <b>Rxn.c</b>	<b>Rxn.o</b>	See 4.1	5.6 / 18
<b>RxSP</b> or <b>Rxt 1</b> etc.	Relay operation independent setpoint or trailing setpoint (*Optional)	<b>RxSP</b> or <b>Rxt 1</b> etc.	<b>RxSP</b>	See 4.1	5.7 / 18
<b>brgt</b>	Display brightness level (manually set)	<b>1</b> to <b>63</b>	<b>63</b>		5.8 / 18
<b>dull</b>	Display remote brightness switching	<b>0</b> to <b>63</b>	<b>15</b>		5.9 / 19
<b>Rx</b> <b>FREE</b>	Alarm relay “free fall” or “in flight” value	Any display value	<b>0</b>	See 4.1	5.10 / 19
<b>P.SET</b>	Preset value	Any display value	<b>0</b>		5.11 / 19
<b>FEC-</b>	Analog output option low display value (*Optional)	Any display value	<b>0</b>		5.12 / 20
<b>FEC+</b>	Analog output option high display value (*Optional)	Any display value	<b>1000</b>		5.13 / 20
<b>FEC-</b> <b>ch2</b>	Second analog output option low display value (*Optional)	Any display value	<b>0</b>		5.14 / 20
<b>FEC+</b> <b>ch2</b>	Second analog output option high display value (*Optional)	Any display value	<b>1000</b>		5.15 / 20
<b>CL.no</b>	Calibration number selection	<b>CAL. 1</b> or <b>CAL.2</b>	<b>CAL. 1</b>		5.22 / 22

(\*Optional)—this function will only be accessible if the relevant option is fitted

Functions in this second table are available only in **CAL** mode or if **ACCS** is set to **ALL**

Display	Function	Range	Default	Your record	Ref/Page
<b>br 9t</b> <b>Auto</b>	Automatic display brightness adjustment	<b>on</b> or <b>OFF</b>	<b>OFF</b>		5.16 / 20
<b>br 9t</b> <b>Hi 9H</b>	Automatic display brightness adjustment - high level	<b>1</b> to <b>63</b>	<b>63</b>		5.17 / 21
<b>br 9t</b> <b>Lo</b>	Automatic display brightness adjustment - low level	<b>1</b> to <b>63</b>	<b>10</b>		5.18 / 21
<b>drnd</b>	Display rounding	<b>1</b> to <b>5000</b>	<b>1</b>		5.19 / 21
<b>dCpt</b>	Decimal point	<b>0</b> , <b>0.1</b> etc.	<b>0</b>		5.20 / 21
<b>FLtr</b>	Digital filter	<b>0</b> to <b>8</b>	<b>2</b>		5.21 / 22
<b>FRtE</b>	Sample rate in samples/sec.	<b>10. 15. 20.</b> <b>30. 40. 50.</b> <b>60. 80</b> or <b>100</b>	<b>10</b>		5.23 / 22
<b>FRGE</b>	mV/V input range	<b>0.5. 1.0. 2.5.</b> <b>5.0. 10. 25.</b> <b>50</b> or <b>100</b>	<b>2.5</b>		5.24 / 23
<b>F: 1P</b>	Remote input (external input) one function	<b>NONE. P.HLd.</b> <b>d.HLd. Hi. Lo</b> <b>.Hi. Lo. tARFE.</b> <b>ZEFO. SP.Ac.</b> <b>No.Ac.</b> <b>CAL.S.P.SET.</b> <b>1.CAL. btch.</b> <b>CAL. 0.Put.</b> <b>dULL</b> or <b>d.SCL.</b> <b>t.Add. t.Clr.</b> <b>t.dSP.</b>	<b>NONE</b>		5.25 / 23
<b>F: 12</b>	Remote input (external input) two function	Same as <b>F: 1P</b>	<b>NONE</b>		5.26 / 26
<b>F: 13</b>	Remote input (external input) three function	Same as <b>F: 1P</b>	<b>NONE</b>		5.27 / 26
<b>Pbut</b>	<b>P</b> button function (for instruments with front <b>P</b> button)	<b>NONE. Hi. Lo.</b> <b>Hi. Lo. tARFE.</b> <b>ZEFO. CAL.S.</b> <b>P.SET. btch.</b> <b>0.Put.</b> <b>t.Add. t.dSP</b> or <b>d.SCL</b>	<b>NONE</b>		5.28 / 26
<b>NEtt</b> <b>FLSH</b>	Nett flash inhibit	<b>on</b> or <b>OFF</b>	<b>OFF</b>		5.29 / 27
<b>ACCS</b>	Access mode	<b>OFF. EASY.</b> <b>NONE</b> or <b>ALL</b>	<b>OFF</b>		5.30 / 27
<b>SPAC</b>	Setpoint access mode	<b>R 1. R 1-2</b> etc.	<b>R 1</b>		5.31 / 27
<b>FREE</b> <b>SPAC</b>	Easy access for alarm relay free fall	<b>on</b> or <b>OFF</b>	<b>OFF</b>		5.32 / 27

(\*Optional)—this function will only be accessible if the relevant option is fitted

<b>LIN PTS</b>	Lineariser points, allows up to 5 calibration points	<b>2, 3, 4</b> or <b>5</b>	<b>2</b>		5.33 / 28
<b>CAL 1</b>	First live calibration point	Any display value	n/a		5.34 / 28
<b>CAL 2</b>	Second live calibration point	Any display value	n/a		5.35 / 28
<b>CAL 3</b>	Third live calibration point	Any display value	n/a		5.36 / 28
<b>CAL 4</b>	Fourth live calibration point	Any display value	n/a		5.37 / 28
<b>CAL 5</b>	Fifth live calibration point	Any display value	n/a		5.38 / 28
<b>ECAL</b>	mV/V entry scaling method	<b>- 19.999</b> to <b>32.000</b>	<b>1.000</b>		5.39 / 29
<b>CAL OFFSE</b>	Calibration offset	Any display value	n/a		5.40 / 29
<b>SET ZERO</b>	Sets zero calibration point	Any display value	n/a		5.41 / 29
<b>ZERO RANGE</b>	Zero range limit	Any display value or <b>OFF</b>	<b>OFF</b>		5.42 / 29
<b>CAL ZERO</b>	Zero reference point for <b>ZERO RANGE</b> operation	n/a	n/a		5.43 / 29
<b>AUTO ZERO</b>	Auto zero range	<b>0</b> to <b>100</b>	<b>0</b>		5.44 / 29
<b>A.Z. CNT</b>	Auto zero sample count	<b>10</b> to <b>100</b>	<b>10</b>		5.45 / 30
<b>ALARM etc.</b>	Alarm relay operation mode	<b>L, UE, BAFE, bECh, P.HLd, d.HLd, H, .Lo</b> or <b>d! SP</b>	<b>L, UE</b>	See 4.1	5.46 / 30
<b>REC or FEC2 or SEFL</b>	Analog or serial operation mode (*Optional)	<b>L, UE, BAFE, P.HLd, d.HLd, H, .Lo</b> or <b>d! SP</b>	<b>L, UE</b>		5.47 / 31
<b>TOTAL</b>	Total mode	<b>L, UE, BAFE, bECh, P.HLd, d.HLd, H, .Lo</b> or <b>d! SP</b>	<b>L, UE</b>		5.48 / 32
<b>Lo d! SP</b>	Low overrange visual warning limit value	Any display value or <b>OFF</b>	<b>OFF</b>		5.49 / 32
<b>Hi SH d! SP</b>	High overrange visual warning limit value	Any display value or <b>OFF</b>	<b>OFF</b>		5.50 / 32
<b>d! SP</b>	Display visual warning flashing mode	<b>FLASH</b> or <b>-or-</b>	<b>FLASH</b>		5.51 / 32
<b>LOG UPdt</b>	Data logger logging period (*Optional)	<b>0.10</b> to <b>60.00</b>	<b>1.00</b>		5.52 / 33

(\*Optional)—this function will only be accessible if the relevant option is fitted

<b>Clr Log</b>	Clear data logger memory (*Optional)	<b>0.10</b> to <b>60.00</b>	n/a		5.53 / 33
<b>SEt rEtC</b>	Set datalogger clock (*Optional)	<b>0.01</b> to <b>24.00</b>	n/a		5.54 / 33
<b>SEt dAtE</b>	Set datalogger date (*Optional)	<b>01.01</b> to <b>31.12</b>	Date		5.55 / 33
<b>SEt YEAr</b>	Set datalogger year (*Optional)	<b>1970</b> to <b>2037</b>	Year		5.56 / 34
<b>bAUd rAtE</b>	Baud rate for serial communications (*Optional)	<b>300.600.</b> <b>1200.2400.</b> <b>4800.9600.</b> <b>19.2</b> or <b>38.4</b>	<b>9600</b>		5.57 / 34
<b>PrEtY</b>	Parity for serial communications (*Optional)	<b>NOtE .EVEN</b> or <b>odD</b>	<b>NOtE</b>		5.58 / 34
<b>O.PUt</b>	Output for serial communications (*Optional)	<b>dI SP .Cont .</b> <b>POLL .A.buS</b> or <b>ā.buS</b>	<b>Cont</b>		5.59 / 34
<b>Addr</b>	Instrument address for serial communications (*Optional)	<b>0</b> to <b>31</b>	<b>0</b>		5.60 / 34
<b>SEr . I tYPE</b>	Serial communications type (*Optional)	<b>NOtE .F232</b> or <b>F485</b>	<b>NOtE</b>		5.61 / 35

(\*Optional)—this function will only be accessible if the relevant option is fitted

## 4.1 Relay table

Record your relay settings in the table below

Display	Relay 1	Relay 2	Relay 3	Relay 4
<b>RxLo</b>				
<b>RxHi</b>				
<b>RxHY</b>				
<b>RxEtE</b>				
<b>RxrtE</b>				
<b>Rxn.o</b> or <b>Rxn.c</b>				
<b>RxSP</b> or <b>RxEt I</b> etc.	n/a			
<b>Rx FFE</b>				
<b>R I.R2</b> etc.				

## 5 Explanation of functions

The LD display setup and calibration functions are configured through a push button sequence. The three push buttons located on the input pcb (also at the front on some display options) are used to alter settings. Two basic access modes are available:

**FUNC** mode (simple push button sequence) allows access to commonly set up functions such as alarm setpoints.

**CAL** mode (power up sequence plus push button sequence) allows access to all functions including calibration parameters.

Once **CAL** or **FUNC** mode has been entered you can step through the functions, by pressing and releasing the **F** push button, until the required function is reached. Changes to functions are made by pressing the **▲** or **▼** push button (in some cases both simultaneously) when the required function is reached.

### Entering **CAL** Mode



1. Remove power from the instrument and wait 5 seconds. Hold in the **F** button and reapply power. The display will indicate **CAL** as part of the "wake up messages" when the **CAL** message is seen you can release the button.  
Move to step 2 below.

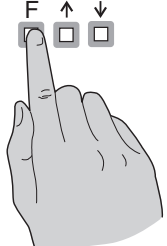

2. When the "wake up" messages have finished and the display has settled down to its normal reading press, then release the **F** button.  
Move to step 3 below.

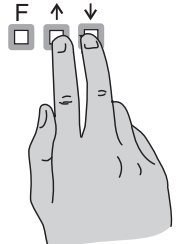

3. Within 2 seconds of releasing the **F** button press, then release the **▲** and **▼** buttons together. The display will now indicate **FUNC** followed by the first function.

Notes: If step 1 above has been completed then the instrument will remain in this **CAL** mode state until power is removed. i.e. there is no need to repeat step 1 when accessing function unless power has been removed. The instrument should show all 8's on power up e.g. **8.8.8.8**. If the instrument does not reset then these numbers will not be seen. Switch off the instrument and allow a longer time delay before powering up again.

### Entering **FUNC** Mode

No special power up procedure is required to enter **FUNC** mode.

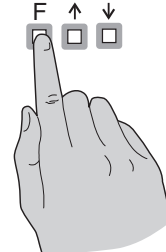

1. When the "wake up" messages have finished and the display has settled down to its normal reading press, then release the **F** button.  
Move to step 2 below.

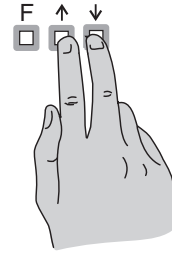

2. Within 2 seconds of releasing the **F** button press, then release the **▲** and **▼** buttons together. The display will now indicate **FUNC** followed by the first function.

### Alternative **CAL** Mode Entry

This alternative method allows **CAL** mode entry without the need to remove power:

1. Enter **FUNC** mode using the 2 steps above
  2. When the first function appears press and hold the **P** button until you see the message **FUNC** followed by **CAL** (the **P** button will have to be held pressed for approximately 2 seconds)
  3. You should now return to the function you were in but have full access to **CAL** mode functions
- Note: when you exit back to live reading the display will remain in **CAL** mode for approximately 4 minutes, after this time you will need to repeat this process to enter **CAL** mode.

### Easy alarm relay adjustment access facility

The display has an easy alarm access facility which allows access to the alarm setpoints simply by pressing the **F** button. The first setpoint will then appear and changes to this setpoint may be made to this setpoint via the **▲** or **▼** buttons. Press the **F** button to accept any changes or to move on to the next

setpoint. The instrument must be set in the manner described below to allow the easy access facility to work:

1. A remote input function such as **FUNC** function must be set to **SPAC** or the **ACCS** function must be set to **ERSY**.
2. At least one alarm must have a setpoint, nothing will happen if all the alarm setpoints are set to **OFF**.
3. The **SPAC** function must be set to allow access to the relays required e.g. if set to **A 1-2** then the easy access will work only with alarm relays 1 and 2.
4. The instrument must be in normal measure mode i.e. if the instrument is powered up so that it is in **CAL** mode then the easy access will not function. If in doubt remove power from the instrument, wait for a few seconds then apply power again.
5. If the easy access facility is used then the only way to view or alter any other function settings is to power up via **CAL** mode i.e. there is no entry to **FUNC** mode functions unless the instrument is powered up in **CAL** mode.

## Explanation of Functions

### 5.1 Alarm relay low setpoint

**Display:** **RxLo**  
**Range:** Any display value or **OFF**  
**Default Value:** **OFF**

Displays and sets the low setpoint value for the designated alarm relay  $x$ . Note  $x$  will be replaced by the relay number when displayed e.g. **R 1Lo** for relay 1. Use this low setpoint function if a relay operation is required when the display value becomes equal to or less than the low setpoint value. To set a low alarm value go to the **RxLo** function and use the **▲** or **▼** push buttons to set the value required then press **F** to accept this value. The low alarm setpoint may be disabled by pressing the **▲** and **▼** push buttons simultaneously. When the alarm is disabled the display will indicate **OFF**. If the relay is allocated both a low and high setpoint then the relay will activate when the value displayed moves outside the band set by the low and high setpoints. The value at which the relay will reset is controlled by the **RxHY** function.

#### Example:

If **R 1Lo** is set to **10** then relay 1 will activate when the display value is 10 or less.

### 5.2 Alarm relay high setpoint

**Display:** **RxH**  
**Range:** Any display value or **OFF**  
**Default Value:** **OFF**

Displays and sets the high setpoint value for the designated alarm relay  $x$ . Note  $x$  will be replaced by the relay number when displayed e.g. **R 1H** for relay 1. Use this high setpoint function if a relay operation is required when the display value becomes equal to or more than the low setpoint value. To set a high alarm value go to the **RxH** function and use the **▲** or **▼** push buttons to set the value required then press **F** to accept this value. The high alarm setpoint may be disabled by pressing the **▲** and **▼** push buttons simultaneously. When the alarm is disabled the display will indicate **OFF**. If the relay is allocated both a low and high setpoint then the relay will activate when the value displayed moves outside the band set by the low and high setpoints. The value at which the relay will reset is controlled by the **RxHY** function.

#### Example:

If **R 1H** is set to **100** then relay 1 will activate when the display value is **100** or higher.



### 5.3 Alarm relay hysteresis (deadband)

**Display:**  $RxHY$   
**Range:** 0 to 9999  
**Default Value:** 10

Displays and sets the alarm relay hysteresis limit for the designated relay  $x$ . Note  $x$  will be replaced by the relay number when displayed e.g.  $R1HY$  for relay 1. To set a relay hysteresis value go to the  $RxHY$  function and use the  $\blacktriangle$  or  $\blacktriangledown$  push buttons to set the value required then press  $\mathbf{F}$  to accept this value. The hysteresis value is common to both high and low setpoint values. The hysteresis value may be used to prevent too frequent operation of the relay when the measured value is rising and falling around setpoint value. e.g. if  $R1HY$  is set to zero the alarm will activate when the display value reaches the alarm setpoint (for high alarm) and will reset when the display value falls below the setpoint, this can result in repeated on/off switching of the relay at around the setpoint value.

The hysteresis setting operates as follows: In the high alarm mode, once the alarm is activated the input must fall below the setpoint value minus the hysteresis value to reset the alarm. e.g. if  $R1H$  is set to  $50.0$  and  $R1HY$  is set to  $3.0$  then the setpoint output relay will activate once the display value goes to  $50.0$  or above and will reset when the display value goes below  $47.0$  i.e. at  $46.9$  or below. In the low alarm mode, once the alarm is activated the input must rise above the setpoint value plus the hysteresis value to reset the alarm. e.g. if  $R1Lo$  is to  $20.0$  and  $R1HY$  is set to  $10.0$  then the alarm output relay will activate when the display value falls to  $20.0$  or below and will reset when the display value goes above  $30.0$  i.e. at  $30.1$  or above. The hysteresis units are expressed in displayed engineering units.

**Example:** If  $R1H$  is set to  $100$  and  $R1HY$  is set to  $10$  then relay 1 will activate when the display value is  $100$  or higher and will reset at a display value of  $89$  or lower.

### 5.4 Alarm relay trip time

**Display:**  $Rxtt$   
**Range:** 0.0 to 999.9  
**Default Value:** 0.0

Displays and sets the alarm trip time in seconds and tenths of seconds. The trip time is common for both alarm high and low setpoint values. The trip time provides a time delay before the alarm relay will activate when an alarm condition is present. The alarm condition must be present continuously for the whole trip time period before the alarm will activate. If the input moves out of alarm condition during this period the timer will reset and the full time delay will be restored. This trip time delay is useful for preventing an alarm trip due to short non critical deviations from setpoint. The trip time is selectable over 0.0 to 999.9 seconds. To set a trip time value go to the  $Rxtt$  function and use the  $\blacktriangle$  or  $\blacktriangledown$  push buttons to set the value required then press  $\mathbf{F}$  to accept this value.

**Example:** If  $R1tt$  is set to  $5.0$  seconds then the display must indicate an alarm value for a full 5 seconds before relay 1 will activate.

### 5.5 Alarm relay reset time

**Display:**  $Rxrt$   
**Range:** 0.0 to 999.9  
**Default Value:** 0.0

Displays and sets the alarm reset delay time in seconds and tenths of seconds. The reset time is common for both alarm high and low setpoint values. With the alarm condition is removed the alarm relay will stay in its alarm condition for the time selected as the reset time. If the input moves back into alarm condition during this period the timer will reset and the full time delay will be restored. The reset time

is selectable over **0.0** to **9999.9** seconds. To set a reset time value go to the **R<sub>rst</sub>** function and use the **▲** or **▼** push buttons to set the value required then press **F** to accept this value.

**Example:** If **R<sub>rst</sub>** is set to **10.0** seconds then the resetting of alarm relay 1 will be delayed by 10 seconds.

## 5.6 Alarm relay normally open/closed

**Display:** **R<sub>xn.o</sub>** or **R<sub>xn.c</sub>**

**Range:** **R<sub>xn.o</sub>** or **R<sub>xn.c</sub>**

**Default Value:** **R<sub>xn.o</sub>**

Displays and sets the setpoint alarm relay *x* action to normally open (de-energised) or normally closed (energised), when no alarm condition is present. Since the relay will always be open open circuit between the NO and COM terminals when power is removed a normally closed alarm is often used to provide a power failure alarm indication. To set the alarm for normally open or closed go to the **R<sub>xn.o</sub>** or **R<sub>xn.c</sub>** function and use the **▲** or **▼** push buttons to set the required operation then press **F** to accept this selection.

**Example:**

If set to **R<sub>1n.o</sub>** alarm relay 1 will be open circuit between the NO and COM terminals when the display is outside alarm condition and will be closed (short circuit across NO and COM terminals) when the display is in alarm condition. The NC and COM terminals will be in the opposite state.

## 5.7 Alarm relay setpoint or trailing operation

**Display:** **R<sub>xSP</sub>** or **R<sub>x<sub>t</sub> i</sub>** etc.

**Range:** **R<sub>xSP</sub>** or **R<sub>x<sub>t</sub> i</sub>** etc.

**Default Value:** **R<sub>xSP</sub>**

Each alarm relay, except relay 1, may be programmed to operate with an independent setpoint value or may be linked to operate at a fixed difference to another relay setpoint, known as trailing operation. The operation is as follows:

Alarm 1 (**R<sub>1</sub>**) is always independent. Alarm 2 (**R<sub>2</sub>**) may be independent or may be linked to Alarm 1. Alarm 3 (**R<sub>3</sub>**) may be independent or may be linked to Alarm 1 or Alarm 2. Alarm 4 (**R<sub>4</sub>**) may be independent or may be linked to Alarm 1, Alarm 2 or Alarm 3. The operation of each alarm is selectable by selecting, for example, (Alarm 4) **R<sub>4.SP</sub>** = Alarm 4 normal setpoint or **R<sub>4.t 1</sub>** = Alarm 4 trailing Alarm 1 or **R<sub>4.t 2</sub>** = Alarm 4 trailing Alarm 2 or **R<sub>4.t 3</sub>** = Alarm 4 trailing Alarm 3. For trailing set points the setpoint value is entered as the difference from the setpoint being trailed. If the trailing setpoint is to operate ahead of the prime setpoint then the value is entered as a positive number and if operating behind the prime setpoint then the value is entered as a negative number.

**Example:** With Alarm 2 set to trail alarm 1, if **R<sub>1H</sub>** is set to **1000** and **R<sub>2H</sub>** is set to **50** then Alarm 1 will activate at **1000** and alarm 2 will activate at **1050** (i.e. 1000 + 50). If Alarm 2 had been set at **-50** then alarm 2 would activate at **950** (i.e. 1000 - 50).

## 5.8 Display brightness (manually set)

**Display:** **br 9t**

**Range:** **1** to **63**

**Default Value:** **63**

Seen only when **br 9t R<sub>Uto</sub>** is set to **OFF**. Displays and sets the digital display brightness. The display brightness is selectable from **1** to **63**, where **1** = lowest intensity and **63** = highest intensity. This

function is useful for improving the display readability in dark areas or to reduce the power consumption of the instrument. See also the **dull** function 5.9. To set brightness level go to the **brgt** function and use the **▲** or **▼** push buttons to set the value required then press **F** to accept this value.

## 5.9 Display remote brightness switching

**Display:** **dull**  
**Range:** **0** to **63**  
**Default Value:** **15**

Displays and sets the level for remote input brightness switching, see **RIOP** function. When a remote input is set to **dull** the remote input can be used to switch between the display brightness level set by the **brgt** function 5.8 and the display brightness set by the **dull** function. The display dull level is selectable from **0** to **63**, where **0** = lowest intensity and **63** = highest intensity. This function is useful in reducing glare when the display needs to be viewed in both light and dark ambient light levels. To set dull level go to the **dull** function and use the **▲** or **▼** push buttons to set the value required then press **F** to accept this value.

### Example:

With **dull** set to **15** and **brgt** set to **63** and the **RIOP** function set to **dull** the display brightness will change from the **63** level to **15** when a switch connected to the remote input terminals is activated.

## 5.10 Alarm relay free fall

**Display:** **Rx FREE**  
**Range:** Any display value  
**Default Value:** **0**

Free fall alarm value - the alarm free fall value is used to provide an offset to the alarm operation. This value can be set anywhere within the measuring range of the instrument and will operate in engineering units e.g. kilograms, tonnes etc. In most applications this function will be used to force the alarm to operate at a given measured quantity prior to the actual alarm relay target weight setting. See also the **FREE SPAC** function 5.32. **Example:**

In a filling application the target weight is 40.0 kg but it is found that due to “in flight” or “free fall” of product the target is consistently 0.5kg over weight. If **R1H** is set to **40.0** and **R1FREE** is set to **0.5** then relay 1 will activate when the display value reaches **39.5**. With 0.5kg of “free fall” this should ensure that the target weight of 40.0kg is reached.

## 5.11 Preset value

**Display:** **P.SET**  
**Range:** Any display value  
**Default Value:** **0**

A preset value can be entered at this function. If a remote input (**RIOP** function) or **P** button (**P.but** function) is programmed to **P.SET** then operation of the remote input or **P** button will cause the display to change to the preset value. Any change in input from this point will cause a variation above or below the preset value. To set preset value go to the **P.SET** function and use the **▲** or **▼** push buttons to set the value required then press **F** to accept this value. **Example:**

With a display showing a value of **50** at a given input if the **P.SET** function is set to **70** and the remote function is set to **P.SET** then once the remote input is activated the same input will now have a display value of **70**.

## 5.12 Analog output option low value

**Display:** **FEE-**  
**Range:** Any display value  
**Default Value:** **0**

Seen only when analog retransmission option fitted. Displays and sets the analog retransmission (4–20mA) output low value (4mA) in displayed engineering units. To set the analog output low value go to the **FEE-** function and use the **▲** or **▼** push buttons to set the required value then press **F** to accept this selection. See also **FEE** function.

**Example:** If it is required to retransmit 4mA when the display indicates **0** then select **0** in this function using the **▲** or **▼** button.

## 5.13 Analog output option high value

**Display:** **FEE^**  
**Range:** Any display value  
**Default Value:** **1000**

Seen only when analog retransmission option fitted. Displays and sets the analog retransmission (4–20mA) output high display value (20mA) in displayed engineering units. To set the analog output high value go to the **FEE^** function and use the **▲** or **▼** push buttons to set the required value then press **F** to accept this selection. See also **FEE** function.

**Example:** If it is required to retransmit 20mA when the display indicates **50** then select **50** in this function using the **▲** or **▼** button.

## 5.14 Second analog output option low value

**Display:** **FEE- Ch2**  
**Range:** Any display value  
**Default Value:** **0**

See **FEE-** function 5.12 for description of operation. See also **FEE** function.

## 5.15 Second analog output option high value

**Display:** **FEE^ Ch2**  
**Range:** Any display value  
**Default Value:** **1000**

See **FEE^** function 5.13 for description of operation. See also **FEE** function.

## 5.16 Automatic display brightness adjustment

**Display:** **brgt AUTO**  
**Range:** **on** or **OFF**  
**Default Value:** **OFF**

Automatic display brightness adjustment. Not applicable unless the optional light sensor is fitted. The automatic brightness adjustment uses the optional light sensor to gauge the required brightness level for

the environment. The high and low brightness limits are set at the **br9t Hi 9H** and **br9t Lo** functions described below. If the light sensor is not fitted this function should be set to **OFF**.

### 5.17 Automatic display brightness adjustment - high level

**Display:** **br9t Hi 9H**  
**Range:** **1 to 63**  
**Default Value:** **63**

Automatic brightness high level - seen only when **br9t Auto** is set to **on**. The high brightness level sets the maximum brightness which the automatic brightness control can achieve with 63 being the highest intensity.

### 5.18 Automatic display brightness adjustment - low level

**Display:** **br9t Lo**  
**Range:** **1 to 63**  
**Default Value:** **10**

Automatic brightness low level - seen only when **br9t Auto** is set to **on**. The high brightness level sets the minimum brightness which the automatic brightness control can achieve with 63 being the highest intensity.

### 5.19 Display rounding

**Display:** **drnd**  
**Range:** **1 to 5000**  
**Default Value:** **1**

Displays and sets the display rounding value. This value may be set to 1 - 5000 displayed units. Display rounding is useful for reducing the instrument resolution without loss of accuracy in applications where it is undesirable to display to a fine tolerance. To set the display rounding value go to the **drnd** function and use the **▲** or **▼** push buttons to set the required value then press **F** to accept this selection.

**Example:** If set to **10** the display values will change in multiples of 10 only i.e. display moves from **10** to **20** to **30** etc.

### 5.20 Decimal point

**Display:** **dCpt**  
**Range:** **0, 0. 1** etc.  
**Default Value:** **0**

Displays and sets the decimal point. By pressing the **▲** or **▼** pushbutton at the **dCpt** function the decimal point position may be set. The display will indicate as follows: **0** (no decimal point), **0. 1** (1 decimal place), **0.02** (2 decimal places), **0.003** (3 decimal places) and **0.0004** for display with more than 4 digits. Note if the decimal point is altered the display will need to be recalibrated and alarm etc. settings checked.

## 5.21 Digital filter

Display: **FLTR**  
Range: **0** to **8**  
Default Value: **2**

Displays and sets the digital filter value. Digital filtering uses a weighted average method of determining the display value and is used for reducing display value variation due to short term interference. The digital filter range is selectable from **0** to **8**, where **0** = none and **8** = most filtering. Use **▲** or **▼** at the **FLTR** function to alter the filter level if required. Note that the higher the filter setting the longer the display may take to reach its final value when the input is changed, similarly the relay operation and any output options will be slowed down when the filter setting is increased. To set the digital filter value go to the **FLTR** function and use the **▲** or **▼** push buttons to set the required value then press **F** to accept this selection.

## 5.22 Calibration number

Display: **CL.no**  
Range: **CAL.1** or **CAL.2**  
Default Value: **CAL.1**

Cell or channel number selection - selects one of the two possible calibration settings (**CAL.1** or **CAL.2**). This function allows the instrument to be calibrated to two different load cells and hold the calibration values in memory. Alternatively two different calibration scaling values may be entered for a single cell. The user may select the load cell to be used via this **CL.no** function or alternatively via the **P** button (if display has a **P** button, and **Pbut** function 5.28 is set to **CAL.5**) or via a remote input (see **CAL.5** function). To scale any of these independent calibration memories you may use any of the methods described in the Chapter 6. Simply select the required cell number then scale using whichever calibration method best suits the application. If a remote input or **P** button is used to select the channel then do not use the **CL.no** function to select the channel i.e. only use one method of selecting the channel. In addition to different scaling the two channels can be set to operate from different decimal point (**dCPE**), sample rate (**FRE**), mV/V range (**RNGE**), lineariser points (**LinPt5**, low and high overrange (**Lo di SP** and **Hi 9H di SP**), display warning type (**di SP**) and zero range **ZERO RNGE** settings. If using this function in conjunction with the remote inputs or **P** button functions then the peak hold, display hold, peak and valley memory, zero, remote input calibrate, and serial print output functions will operate individually for each channel, the tare command will tare both channels simultaneously. Other remote input and **P** button functions are not intended for use with the channel selection function.

## 5.23 Sample rate

Display: **FRE**  
Range: **10.15.20.30.40.50.60.80** or **100**  
Default Value: **10**

Displays and sets the input sample rate from 10 to 100 samples per second. Note: the display updates approx. 4 times per second. The faster sample rates can be utilised in features such as peak hold, peak/valley memory, analog or digital retransmission and serial communications.

## 5.24 mV/V input range

Display: **RNGE**  
Range: **0.5 . 1.0 . 2.5 . 5.0 . 10 . 25 . 50** or **100**  
Default Value: **2.5**

Displays and sets the mV/V (milli Volt output per Volt of excitation) range to suit the transducer useable range. For example a transducer with 2mV/V output will have a theoretical output from 0mV at no load to 20mV at full specified load if 10V excitation is used. Check the transducer label or transducer calibration sheet or brochure for mV/V specification. Choose the value equal to or the next higher value to the mV/V output of the transducer. This selection sets the input range for the A/D converter. If too low a range is selected a “ - - - ” error message may be seen on the display when a load is applied. If too high a range is selected the full resolution capability will not be used and problems with calibration can result - see “Error messages” section.

## 5.25 Remote input function

Display: **F.I NP**  
Range: **NONE . P.HLD . d.HLD . H<sub>i</sub> . Lo . H<sub>i</sub> Lo . tARE . 2EFO . SP.Ac . No.Ac . CAL.S . P.SET . i.CAL . b.tch . CAL<sub>i</sub> . O.Put<sub>i</sub> . dULL or d.SCL . t.Add . t.CLR . t.dSP.**  
Default Value: **NONE**

Remote input function - When these remote input terminals are short circuited, via a switch, relay, keyswitch etc. the instrument will perform the selected remote input function. A message will flash to indicate which function has been selected when the remote input pins are short circuited. The remote input functions are as follows:

**NONE** - no remote function required i.e. activating the remote input has no effect.

**P.HLD** - peak hold. The display will show the peak value (highest positive value) only whilst the remote input terminals are short circuited i.e. the display value can rise but not fall whilst the input terminals are short circuited. The message **P.HLD** will appear briefly every 8 seconds whilst the input terminals are short circuited to indicate that the peak hold function is active.

**d.HLD** - display hold. The display value will be held whilst the remote input terminals are short circuited. The message **d.HLD** will appear briefly every 8 seconds whilst the input terminals are short circuited to indicate that the display hold function is active.

**H<sub>i</sub>** - peak memory. The peak value stored in memory will be displayed if the remote input terminals are short circuited, if the short circuit is momentary then the display will return to normal measurement after 20 seconds. If the short circuit is held for 2 to 3 seconds or the power is removed from the instrument then the memory will be reset.

**Lo** - valley memory. The minimum value stored in memory will be displayed. Otherwise operates in the same manner as the **H<sub>i</sub>** function described above.

**H<sub>i</sub> Lo** - toggle between **H<sub>i</sub>** and **Lo** displays. This function allows the remote input to be used to toggle between peak and valley memory displays. The first operation of the remote input will cause the peak memory value to be displayed, the next operation will give a valley memory display. **P.H<sub>i</sub>** or **P.Lo** will flash before each display to give an indication of display type.

**tARE** - display tare. Short circuiting the remote input pins momentarily will allow toggling between nett and gross values (shown as **NETT** and **GRGS**). If the remote input is short circuited for approx. 2 seconds the display will be tared and will show zero. The tare will be lost if power is removed.

**ZERO** - display zero. Zeroes the display in same manner as the tare function except that the zero is not lost when power is removed and the display will zero as soon as the remote input is shorted. When the **ZERO** operation is used the gross value cannot be recalled and the input at the time of the **ZERO** operation will become the new zero point.

**SP.Ac** - setpoint access only. This blocks access to any functions except the alarm setpoint functions unless the remote input pins are short circuited or entry is made via **CAL** mode or if the **ACCS** function is set to **ALL**.

**No.Ac** - no access. This blocks access to all functions unless the remote input pins are short circuited or entry is made via **CAL** mode or if the **ACCS** function is set to **ALL**.

**CAL.S** - calibration select. The remote input can be used to select between calibration scaling values. Two sets of calibration scalings can be entered in the display, one set with the remote input terminals open circuit and another set with the remote input terminals short circuit to ground. The remote input can then be used to switch between one set and the other. This allows two different load cells to be connected with a remote input being used to select the correct scaling for each or the same load cell could be used and the remote input used to toggle between different display units e.g. between Newtons and kilograms. Note: Alarm settings will not change when changing between calibrations scales. Only one set of alarm functions can be made and the alarm relay will operate from those set values no matter which calibration scale is being viewed at the time. The **dCPE**, **FAE**, **RAE**, **L.nPES**, **Lo di SP**, **Hi GH di SP**, **di SP** and **ZERO RAE** functions can be individually set for each channel. If **P.SET** is used only one preset value can be used but only the channel displayed at the time is affected. Note; using different **dCPE** settings between channels will affect the preset and alarm setpoint values e.g. a preset of **25** on a channel with **dCPE = 0** will become **2.5** on a channel with **dCPE = 0.1**. Note: the **CL.no** function can also be used to perform the same calibration select function as the **CAL.S** setting. Use only one of these methods to change selection as they will counteract each other if both are used.

**P.SET** - preset value. The remote input can be used to force the display to the preset value, this preset value is set at the **P.SET** function.

**I.CAL** - Initiate auto calibration - not available on all software versions - this function allows the user to select when an auto calibration takes place rather than relying on the instruments normal internal calibration which may cause the output to pause. Closing the external input will cause an internal calibration to take place. If the input is held closed then an internal calibration will take place periodically.

**batch** - the batch function does not affect the display value when operated. It does, however affect the retransmission and alarm functions, see Chapter 7 for a full description.

**CAL** - Calibration, when set to **CAL** the remote input can be used to perform a calibration. See Chapter 6 for details.

**t.Add** - add to total. A totaliser facility is provided whereby the user can add displayed weights to a totaliser memory. When this mode is selected for a given remote input the weight displayed at the time of remote input operation will be added to the total memory when the input is operated. The message **Add** will be seen to indicate that the value has been added. The total can be viewed or cleared using the two functions which follow. For example remote input 1 could be set to **t.Add**, remote input 2 to **t.CLR** and remote input 3 to **t.dSP**. This would allow the three remote inputs to be used for the adding, clearing and displaying functions.

**t.CLR** - clear the total. When this mode is selected operation of the chosen remote input will cause the total memory to be cleared. The message **CLR** will precede the memory clearing.

**t.dSP** - display total. When this mode is selected operation of the chosen remote input will cause the total memory value to be displayed. The message **tot!** will precede the total value display.

**Q.PUt** - serial "print" output - applicable only when the serial output option is fitted - allows the remote input to be used to initiate a single serial string output. The value output can be set to the live



input value, the display value or one of the appropriate remote input functions. If a remote input function is selected such as **H, Lo** then in addition to the serial output function (**SEFL**) being selected as **H, Lo** a remote input (**F.I NP, F.I N2** or **F.I N3**) or the **P** button (**Pbut**) function must also be set to **H, Lo**. The serial output will be a single string beginning with a start of text character <STX> and ending with a carriage return <CR> the value will occur between these two control characters. In the case of a **H, Lo** operation the high value will be separated from the low value by a comma. e.g.:

<STX>Hi value, Lo value<CR>.

The transmitted string is in standard ASCII format. The functions required for this “print” output command are:

**Pbut, F.I NP, F.I N2** and **F.I N3** - one of these functions must be set to **Q.Put**. When the selected remote input is shorted to ground or the **P** button is pressed a single serial string of the value selected will be transmitted.

**Q.Put** - this function must be set to **POLL**. When set to **POLL** the instruments serial communications can operate as either a “print” output or in the conventional polling mode.

**SEFL** - this function sets the value to be transmitted when using “print” output operation. The options are:

**L, UE** (live reading), the value sent will be the live input value determined from the calibration scaling and the level of the electrical input from the load cell or sensor.

**TARE** (tare), the value sent will follow the tared value when a remote input or **P** button has been used to tare the display.

**batch** (batch), the value sent will follow the batch value when a remote input or **P** button has been used for batch operation.

**P.HLd** (peak hold), the value sent will be the peak value whilst the peak hold operation is in progress i.e. When a remote input is being used to cause a peak hold display. The value will be reset when the **P.HLd** remote input is deactivated.

**d.HLd** (display hold), the value sent will be the held display value whilst the display hold operation is in progress i.e. When a remote input is being used to cause a display hold. The value will be reset when the **d.HLd** remote input is deactivated.

**H,** (peak memory), the value sent will be the peak value in memory. This can be reset by activating the **H,** remote input or **P** button for 2 seconds or by removing power to the instrument.

**Lo** (valley memory), the value sent will be the lowest value in memory. This can be reset by activating the **Lo** remote input or **P** button for 2 seconds or by removing power to the instrument.

**d: SP** (display value), the value transmitted will be whatever value is on the display at the time of a “print” operation.

**H, Lo** (peak, valley memory), the values sent will be the peak value in memory followed by a comma followed by the lowest value in memory. These can be reset by activating the **H, Lo** remote input or **P**

#### Example:

To make the serial “print” output send the peak held value using remote input 1 as the peak hold remote input and the **P** button as the “print” input:

1. Set the **F.I NP** function to **P.HLd**
2. Set the **Pbut** function to **Q.Put**
3. Set the **Q.Put** function to **POLL**
4. Set the **SEFL** function to **P.HLd**

Whilst the remote input 1 terminal is short circuited to the GND terminal the display will show the peak held value. When the **P** button is pressed a single serial string showing the peak held value will be transmitted.

**dull** - display brightness control. The remote input can be used to change the display brightness. When this mode is selected the display brightness can be switched, via the remote input terminals, between the brightness level set at the **brgt** function and the brightness level set at the **dull** function.

**d.SCL** - applicable only if the dummy load option board is fitted. When the dummy load option board is fitted this option allows the input to be switched from the load to the dummy load. When the dummy load is activated the display will show the scaling value for the dummy load. The scaling value should be noted once installation is complete. Note that if the display is re calibrated or zeroed then the scaling value for the dummy load will change and a note of the new value should be taken. The tare operation will not alter the dummy load scaling value. An adjustment screw allows some adjustment of the value displayed. Whilst the dummy load is connected the display will flash the message **d.SCL** approximately once every 8 seconds. If the dummy load is activated via a momentary action switch (or via the front **P** button) the display will revert back to a normal live input display value after 20 seconds. If a latching switch is used to activate the dummy load then the display will show the dummy load value and flash the **d.SCL** message until 20 seconds after the remote input is released. For 5 digit displays the activation of the dummy load will also cause the "A2" annunciator LED to light during the duration of the dummy load display. The value shown for the dummy load does not affect normal relay or retransmission operations.

## 5.26 Remote input two function

Display: **r.1 n2**  
Range: Same as **r.1 nP**  
Default Value: **none**

Remote input two function - As per **r.1 nP** function but uses remote input 2.

## 5.27 Remote input three function

Display: **r.1 n3**  
Range: Same as **r.1 nP**  
Default Value: **none**

Remote input three function - As per **r.1 nP** function but uses remote input 3.

## 5.28 **P** button function

Display: **Pbwt**  
Range: **none, H, Lo, H, Lo, tARE, ZERO, CAL.S, P.SET, btch, O.Pwt, t.Add, t.dSP** or **d.SCL**  
Default Value: **none**

**P** button function - a only applicable models with front panel **P** buttons. The **P** button may be set to operate some of functions also available via the remote input, see **r.1 nP** 5.25 for a description of these functions. The **P** button is located at the front of 5 or 6 digit LED models and bargraph models. If both the remote input and **P** button function are operated simultaneously the **P** button will override the remote input.

Note: To prevent accidental operation of the **P** button in the **tARE** or **ZERO** functions it is necessary to hold the button in for 2 seconds to perform the selected operation.

## 5.29 Nett flash inhibit

Display: **NETT FLSH**  
Range: **on** or **OFF**  
Default Value: **OFF**

Nett value display mode - the nett value is only seen when a remote input function e.g. **F.I NP** or **P** button **Pbut** function is set to **SAFE** and can therefore toggle between gross and nett displays. The **NETT FLSH** function can be set to **on** or **OFF**. If set to **on** then the message **NETT** will flash briefly approximately every 6 seconds when the operator toggles to a nett display to remind the operator that a nett value is being viewed. If set to **OFF** then the message **NETT** will flash briefly once only when the operator toggles to the nett value.

## 5.30 Access mode

Display: **ACCS**  
Range: **OFF.EASY.NONE** or **ALL**  
Default Value: **OFF**

The access mode function **ACCS** has four possible settings namely **OFF.EASY.NONE** and **ALL**. If set to **OFF** the mode function has no effect on alarm relay operation. If set to **EASY** the “easy alarm access” mode will be activated, see page 15. If set to **NONE** there will be no access to any functions via **FUNC** mode, entry via **CAL** mode must be made to gain access to alarm and calibration functions. If set to **ALL** then access to all functions, including calibration functions, can be gained via **FUNC** mode.

## 5.31 Setpoint access mode

Display: **SPAC**  
Range: **A 1.A 1-2** etc.  
Default Value: **A 1**

Setpoint access - sets the access via **FUNC** mode and “easy alarm access” mode to the alarm relay setpoints. The following choices are available:

**A 1** - Allows setpoint access to alarm 1 only.

**A 1-2** - Allows setpoint access to alarms 1 and 2 only.

**A 1-3** - Allows setpoint access to alarms 1,2 and 3 etc. up to the maximum number of relays fitted.

A remote input function e.g. (**F.I NP**) must be set to **SPAC** for this function to operate. Note: Only the setpoints which have been given a value will be accessible e.g. if **A 1H** is set to **OFF** then there will be no access to the **A 1H** function when **SPAC** is used.

## 5.32 Easy access for alarm relay free fall

Display: **FREE SPAC**  
Range: **on** or **OFF**  
Default Value: **OFF**

Easy access to free fall alarm values - When set to **on** allows the free fall alarm values to be access via “Easy access” mode, see page 15 for a description. If more than one relay is fitted to the instrument only the relays selected at the **SPAC** function above will have easy access. If set to **OFF** the free fall values are not available in “Easy access” and any changes to the values must be done at the **Ax FREE** function.

### 5.33 Lineariser points

**Display:** **L, n Pts**  
**Range:** **2, 3, 4** or **5**  
**Default Value:** **2**

Lineariser points - see section 6.1. Displays and sets the number of calibration scaling points to be used.

### 5.34 First live calibration point

**Display:** **CAL 1**  
**Range:** Any display value  
**Default Value:** n/a

Calibration scaling first point - see section 6.1.

### 5.35 Second live calibration point

**Display:** **CAL 2**  
**Range:** Any display value  
**Default Value:** n/a

Calibration scaling second point - see section 6.1.

### 5.36 Third live calibration point

**Display:** **CAL 3**  
**Range:** Any display value  
**Default Value:** n/a

Calibration scaling third point, seen only when **L, n Pts** is set to **3, 4** or **5** - see section 6.1.

### 5.37 Fourth live calibration point

**Display:** **CAL 4**  
**Range:** Any display value  
**Default Value:** n/a

Calibration scaling fourth point, seen only when **L, n Pts** is set to **4** or **5** - see section 6.1.

### 5.38 Fifth live calibration point

**Display:** **CAL 5**  
**Range:** Any display value  
**Default Value:** n/a

Calibration scaling fifth point, seen only when **L, n Pts** is set to **5** - see section 6.1.

### 5.39 mV/V entry scaling method

**Display:** **ECAL**  
**Range:** **- 19.999 to 32.000**  
**Default Value:** **1.000**

mV/V scaling, seen only when **L, n Pts** is set to **2** - see section 6.2

### 5.40 Calibration offset

**Display:** **CAL OFFSt**  
**Range:** Any display value  
**Default Value:** n/a

Calibration offset - See section 6.3.

### 5.41 Set zero

**Display:** **SEt ZER0**  
**Range:** Any display value  
**Default Value:** n/a

Set zero point - see section 6.5.

### 5.42 Zero range

**Display:** **ZER0 RnGE**  
**Range:** Any display value or **OFF**  
**Default Value:** **OFF**

Zero range limit value - see section 6.6.

### 5.43 Zero reference point for **ZER0 RnGE** operation

**Display:** **CAL ZER0**  
**Range:** n/a  
**Default Value:** n/a

Zero point calibration for **ZER0 RnGE** function - see section 6.7.

### 5.44 Auto zero range

**Display:** **Aut0 ZER0**  
**Range:** **0 to 100**  
**Default Value:** **0**

The display can be set to automatically zero its reading if the display is within the range set by the **Aut0 ZER0** function for the set number of samples, see **A.2. cont 5.45**. For example if the auto zero is set to **10** then the instrument will re-zero itself whenever the display is within **10** units of zero for the set number of samples i.e. between **- 10** and **10**. Setting auto zero to **0** will disable the function and the instrument will not zero automatically. The time taken to auto zero depends upon the sample rate and

the sample count **R.2. cnt** setting. Note the **Auto ZERO** range is in counts and has not decimal points so for example to auto zero from -10.0 to 10.0 display units the **Auto ZERO** setting would be 100 rather than 10.

### 5.45 Auto zero sample count

Display: **R.2. cnt**  
Range: **10 to 100**  
Default Value: **10**

Displays and sets the number of samples to be taken for the auto zero function **Auto ZERO**. For example if set to **50** then if the display is within the auto zero setting (e.g. **10**) for 50 samples then the instrument will automatically zero.

### 5.46 Alarm relay operation mode

Display: **R 1, R2** etc.  
Range: **L, UE, TARE, batch, P.HLd, d.HLd, H, Lo** or **di SP**  
Default Value: **L, UE**

Alarm relay operation mode for relays 1, 2 etc. The following choices are available for alarm operation mode:

**L, UE** - live input mode. The alarm relay operation will always follow the electrical input at that time irrespective of the 7 segment display value. e.g. assume the remote input is set to **TARE** and **R 1H** is set to **100**. If the instrument is tared at a display reading of **30** then the alarm will now activate at a display reading of **70**. Note that the **L, UE** mode does not follow the electrical input if a remote input or **P** button **ZERO** operation has been undertaken. This is due to the fact that the **ZERO** operation shifts the display calibration.

**TARE** - tare mode. The alarm relay operation will follow the tare function. e.g. in the example above (**L, UE**) if **R 1** is set to **TARE** then the alarm would activate at a display reading of **100** (the setpoint value) rather than **70**.

**batch** - batch mode. The alarm relay operation will follow the batch mode operation when the **F.1 NP**, **F.1 N2**, **F.1 N3** or **Pbut** function is set to **batch**. See section 5.25.

**P.HLd** - peak hold mode. When **P.HLd** is selected and the remote input is set to peak hold (**P.HLd**) then once the peak display goes above any alarm high setpoint the alarm relay will activate and will not de-activate until the peak hold is released and the display value falls below the setpoint value.

**d.HLd** - display hold mode. When **d.HLd** is selected and the remote input is set to display hold (**d.HLd**) then the alarm relay will be held in its present state (activated or de-activated) until the display hold is released and the display is free to change.

**H** - peak (max.) memory mode. When **H** is selected and the remote input is set to peak memory (**H**) then the alarm will be activated if the peak memory value is above the high setpoint value. The alarm will not de-activate until the memory is reset.

**Lo** - valley (min.) memory mode. When **Lo** is selected and the remote input is set to valley memory (**Lo**) then the alarm relay will be activated if the valley memory value is below the low setpoint value. The alarm will not de-activate until the memory is reset.

**di SP** - display mode. When **di SP** is selected the alarms will operate purely on the display value at the time i.e. if the display is showing above high setpoint or below the low setpoint value then the alarm relay will activate.

## 5.47 Analog or serial operation mode

**Display:** *rEC* or *rEC2* or *SEFL*  
**Range:** *L, UE, tARFE, P.HLd, d.HLd, H, Lo* or *d: SP*  
**Default Value:** *L, UE*

This section describes the operation modes available for the retransmission options *rEC* (analog retransmission) operation mode or *rEC2* (second analog retransmission) or *SEFL* (serial retransmission). The following choices are available:

*L, UE* - live input mode. The retransmission will follow the electrical input and will not necessarily follow the 7 segment display. For example if the remote input is set for peak hold operation then when the remote input is closed the 7 segment display will only show the peak value but the retransmission will be free to change to follow the electrical input. Note that the *L, UE* mode does not follow the electrical input if a remote input or **P** button *ZEFO* operation has been undertaken. This is due to the fact that the *ZEFO* operation shifts the display calibration.

*tARFE* - tare mode. The retransmission value will tare (fall to zero) along with 7 segment display when the remote input tare function is operated. If the remote input toggles the 7 segment display to show gross (*GFOS*) then the 7 segment display will change to show the gross value but the retransmission will not respond see *L, UE* for alternative operation.

*P.HLd* - peak hold mode. The 7 segment display and retransmission value will indicate the peak value only whilst the peak value function is operated via a contact closure on the remote input i.e. the 7 segment display and retransmission can rise but not fall whilst the remote input switch is closed. When the remote input switch is opened the retransmission value will remain fixed i.e. it will not rise or fall, although the 7 segment display value will be free to alter. This peak retransmission output can be cleared by closing the remote input switch for another operation or by removing power from the instrument. Note: In this mode the retransmission will show a zero reading until the remote input is operated for the first time after switch on.

*d.HLd* - display hold mode. The 7 segment display and retransmission value will be held whilst the remote input display hold switch is closed. When the switch is opened the retransmission value will remain fixed at the held value although the 7 segment display value will be free to alter. The held retransmission output can be cleared by closing the remote input switch for another operation or by removing power from the instrument. Note: In this mode the bargraph will show a zero reading until the remote input is operated for the first time after switch on.

*H* - peak (max.) memory mode. With the peak remote input switch open the retransmission will indicate the peak value in memory i.e. the retransmission output can rise but not fall. The retransmission output can be reset by clearing the memory. The memory may be cleared either by closing the remote input switch for approximately 2 seconds or by removing power to the instrument.

*Lo* - valley (min.) memory mode. With the valley remote input switch open the retransmission will indicate the valley (min.) value in memory i.e. the retransmission output can fall but not rise. The retransmission output can be reset by clearing the memory. The memory may be cleared either by closing the remote input switch for approximately 2 seconds or by removing power to the instrument.

*d: SP* - display mode. The retransmission output will follow whatever value is on the 7 segment display. For example if the remote input is set to *tARFE* then the 7 segment and retransmission output will indicate the tared value and both will also be changed if the remote input toggles the displays between *rEtt* and *GFOS*. If the *rEC* had been set to *tARFE* then the retransmission output would not respond to the *GFOS* toggle.

## 5.48 Total mode

**Display:** **tot**  
**Range:** **L, UE, tAFE, bECh, P,HLd, d,HLd, H, .Lo** or **d: SP**  
**Default Value:** **L, UE**

Totaliser memory display mode. This function allows the totaliser memory to operate in the same modes as the alarm and retransmission modes described above. Ensure that the **F: A1**, **F: A2** or **F: A3** or **Pbut** function is also set to the desired operation.

## 5.49 Low overrange visual warning limit value

**Display:** **Lo d: SP**  
**Range:** Any display value or **OFF**  
**Default Value:** **OFF**

Low overrange limit value - the display can be set to show an overrange message if the display value falls below the **Lo d: SP** setting. For example if **Lo d: SP** is set to **50** then once the display reading falls below **50** the message **-or-** will flash on and off or the display value will flash on and off instead of the normal display units (see **d: SP** function 5.51). This message can be used to alert operators to the presence of an input which is below the low limit. If this function is not required it should be set to **OFF** by pressing the **▲** and **▼** buttons simultaneously at this function.

## 5.50 High overrange visual warning limit value

**Display:** **Hi 9H d: SP**  
**Range:** Any display value or **OFF**  
**Default Value:** **OFF**

High overrange limit value - the display can be set to show an overrange message if the display value rises above the **Hi 9H d: SP** setting. For example if **Hi 9H d: SP** is set to **1000** then once the display reading rises above **1000** the message **-or-** will flash on and off or the display value will flash on and off instead of the normal display units (see **d: SP** function 5.51). This message can be used to alert operators to the presence of an input which is above the high limit. If this function is not required it should be set to **OFF** by pressing the **▲** and **▼** buttons simultaneously at this function.

## 5.51 Display visual warning flashing mode

**Display:** **d: SP**  
**Range:** **FLSH** or **-or-**  
**Default Value:** **FLSH**

Display overrange warning flashing mode - this function is used in conjunction with the **Lo d: SP** and **Hi 9H d: SP** functions. The **d: SP** function can be set to **FLSH** or **-or-**. If the display warning value set at the **Lo d: SP** or **Hi 9H d: SP** function is exceeded and the **d: SP** function is set to **FLSH** then the display value will flash on and off every second as a visual warning. If the display warning value set at the **Lo d: SP** or **Hi 9H d: SP** function is exceeded and the **d: SP** function is set to **-or-** then the **-or-** message will flash on and off once a second as a visual warning. The warning flashes will cease and the normal display value will be seen when the value displayed is higher than the low limit and lower than the high limit.



## 5.52 Data logger logging period

**Display:** **LOG UPdt**  
**Range:** **0.10** to **60.00**  
**Default Value:** **1.00**

Select log update time - seen only with data logger option. Refer to section 11 .

Displays and sets the time period between each log sample. Available selections are:

0.10 (10 seconds), 0.20 (20 seconds), 0.30 (30 seconds), 1.00 (1 minute), 2.00 (2 minutes), 3.00 (3 minutes), 4.00 (4 minutes), 5.00 (5 minutes), 6.00 (6 minutes), 10.00 (10 minutes), 15.00 (15 minutes), 20.00 (20 minutes), 30.00 (30 minutes) and 60.00 (60 minutes).

Note: The data log memory (see **Clr LOG** below) must be cleared whenever the log update time is changed or the date and time is changed.

## 5.53 Clear data logger memory

**Display:** **Clr LOG**  
**Range:** **0.10** to **60.00**  
**Default Value:** n/a

Clear data log memory - seen only with data logger option. Refer to section 11 .

This function clears the data log memory, to clear the memory press then release **▲** and **▼** simultaneously, the display will show **Clr?** asking if you really want to clear the memory. If you wish to clear memory then press then release **▲** and **▼** simultaneously again. The log memory will then be cleared and the log period reset, the display will indicate **Prog LOG** to confirm this. Once the memory is cleared all previously logged records will be lost from the instruments memory, if the **Clr?** message is reached and it is not wished to clear the log memory then pressing and releasing either **F** or **P** will abort the function.

## 5.54 Set datalogger clock

**Display:** **SEt rtc**  
**Range:** **0.01** to **24.00**  
**Default Value:** n/a

Set time - seen only with data logger option. Refer to section 11 .

Displays and sets the current time in hours and minutes (24 hour format HH.MM) e.g. set as **17.20** for 5:20 pm.

## 5.55 Set datalogger date

**Display:** **SEt dAtE**  
**Range:** **01.01** to **31.12**  
**Default Value:** Date

Set date - seen only with data logger option. Refer to section 11 . Displays and sets the current date in days and months (DD.MM format). The months will roll over automatically (up at the end of the month, down at the beginning of the month) as the day is scrolled up or down.

## 5.56 Set datalogger year

**Display:**            **SEt YEAr**  
**Range:**             **1970 to 2037**  
**Default Value:**    Year

Set year - seen only with data logger option. Refer to section 11 . Displays and sets the current year (YYYY format). Valid years settings are from 1970 to 2037 (valid Julian time format years).

## 5.57 Baud rate for optional serial communications

**Display:**            **bAUD rAtE**  
**Range:**             **300 . 600 . 1200 . 2400 . 4800 . 9600 . 19.2 or 38.4**  
**Default Value:**    **9600**

Set baud rate - seen only with serial output option. Select from **300 . 600 . 1200 . 2400 . 4800 . 9600 . 19.2** or **38.4** baud. Refer to Chapter 8, page 44 .

## 5.58 Parity for optional serial communications

**Display:**            **PrEtY**  
**Range:**             **NOtNE . EVEN or odd**  
**Default Value:**    **NOtNE**

Set parity - seen only with serial output option. Select parity check to either **NOtNE** , **EVEN** or **odd**. Refer to Chapter 8, page 44 .

## 5.59 Output mode for optional serial communications

**Display:**            **0.PUt**  
**Range:**             **d! SP . Cont . POLL . R.buS or ~.buS**  
**Default Value:**    **Cont**

Set serial interface mode - seen only with serial output option. Refer to Chapter 8, page 44 . Allows user to select the serial interface operation as follows:

**d! SP** - sends image data from the display without conversion to ASCII.

**Cont** - sends ASCII form of display data at a rate typically 90% of the sample rate.

**POLL** - controlled by computer or PLC as host. Host sends command via RS232/485 and instrument responds as requested.

**R.buS** - is a special communications mode used with Windows compatible optional PC download software. Refer to the user manual supplied with this optional software.

**~.buS** - Modbus RTU protocol.

## 5.60 Instrument address for optional serial communications

**Display:**            **Addr**  
**Range:**             **0 to 31**  
**Default Value:**    **0**

Set unit address for polled (**POLL**) mode (**0 to 31**) - seen only with serial output option. Allows several units to operate on the same RS485 interface reporting on different areas etc. The host computer or PLC

may poll each unit in turn supplying the appropriate address. The unit address ranges from 0 to 31 (DEC) but is offset by 32 (DEC) to avoid clashing with ASCII special function characters (such as <STX> and <CR>). Therefore 32 (DEC) or 20 (HEX) is address 0, 42 (DEC) or 2A (HEX) is address 10. Refer to Chapter 8, page 44 .

### 5.61 Serial communications type

Display: **SEF. TYPE**  
Range: **NONE, F232** or **F485**  
Default Value: **NONE**

Selects the serial output communications type from: **NONE** for no serial output, **F232** for RS232 output or **F485** for RS485 output. Note that the serial output is optional and factory configured with the hardware for one particular type of output i.e. if fitted with RS232 hardware then both the **SEF. TYPE** and the hardware must be changed to convert to RS485.

### 5.62 Returning to normal measure mode

When the calibration has been completed it is advisable to return the instrument to the normal mode (where calibration functions are less likely to be tampered with). To return to normal mode, turn off power to the instrument, wait a few seconds and then restore power.

### 5.63 Error messages

**SPAN Err** - calibration span error. Live inputs used at **CAL 1** and **CAL 2** or other live calibration points are too close in value. The change in mV input or load applied to the cell must be at least 10% of the full range or capacity of the cell between live input calibration points. Recalibrate using inputs further apart in value. If you are certain that the inputs are far enough apart but still see the **SPAN Err** message then ignore the message and continue with the calibration. At the end of the calibration check to see if the display calibration is correct and if not recalibrate using the same inputs. If the error message persists check that the output from the load cell has changed sufficiently by measuring the mV output at no load and with the calibration load applied. See also the **Using the INPT display to test input level** section which follows for an easy method of checking the input level.

**CAL Err** - This indicates that one of the calibration points has caused an overrange error in the analog to digital converter. Check the mV output from the load cell and check that the **RNGE** function setting is set to the correct range for the load cell used.

**ZERO RNGE Err** - Zero range error. Caused by an attempt to zero the display outside the allowed range. See **ZERO RNGE** function ref. 6.6.

**ADC GAIN Err** - This indicates that when an **ECAL / ESCL** method of calibration has been used the mV/V figure entered at the **ECAL** function is greater than the mV/V range entered at the **RNGE** function. The **RNGE** function should be set to be equal the **ECAL** value or to the next available value higher than the **ECAL** value.

**tbLE Err** or **L, n tbLE Err** - these error messages indicate that the **L, n PLS** function is set to a value of 3, 4 or 5 i.e. multipoint calibration for linearisation is selected and that an error in the polarity of the input has occurred. When using more than 2 calibration points it is essential that each input is greater than the previous point by at least 10% of the input range and is greater in the positive direction than the previous point. If a calibration point is seen to be more negative than the previous one the **tbLE Err** will be seen after the calibration for that point is attempted. The **L, n tbLE Err** error message will be seen at power up if there has been such a calibration error and it has not been corrected. If the signal is increasing negatively then check wiring of the load

cell/pressure sensor. See also the **Using the *I NPE* display to test input level** section which follows for an easy method of checking the input level.

**Unstable display** - if the display is not stable the usual cause is either that the input signal is unstable or that the calibration scaling was incorrectly attempted. Measure the load cell mV input to check for stability. If the mV input is stable recalibrate the display. See also the **Using the *I NPE* display to test input level** section which follows for an easy method of checking the input level.

**Display shows “ - - - - ”** - this message indicates that the input signal is higher than the range selected. Check that the **RNGE** function is set to the correct mV/V for the load cell used. If this is set correctly check that the mV input at the Signal + and Signal - terminals is within the range selected. e.g. if **RNGE** is set to **2.5** and the excitation voltage is set to 10V then the input mV signal at the Signal + and Signal - terminals should be no greater than 25mV.





**Display shows -or-** - this message indicates either that the number is too big to display e.g. above **9999** on a 4 digit display or that the **di SP** function has been set to **-or-** and either the **Lo di SP** or **Hi 9H di SP** limits have been exceeded. You can check if this is the problem by setting the **di SP** function to **FLASH** which will cause the display value rather than the **-or-** message to flash if the limits set have been exceeded. If the **di SP** setting is not the problem then try recalibrating the display. If the **-or-** message is seen during calibration ignore it proceed with the calibration then check the display reading again after calibration. See also the **Using the *I NPE* display to test input level** section which follows for an easy method of checking the input level.

**Display value flashes on and off** - this indicates that the **di SP** function ref 5.51 has been set to **FLASH** and either the **Lo di SP** or **Hi 9H di SP** function limits set have been exceeded.

**NO ACCS** - This display mean that function access has been denied. This will be due to either one of the remote input functions (**F.I NP**, **F.I N2** or **F.I N2**) being set to **NO.Ac** or that the **ACCS** function being set to **NONE**. To override the remote input functions and gain access you can either place a short circuit between the appropriate remote input and ground or power up the instrument in **CAL** mode. To override the **ACCS** function you must power up in **CAL** mode.

**NO SPAC** - This display mean that function access has been denied. This will be due to either one of the remote input functions (**F.I NP**, **F.I N2** or **F.I N3**) being set to **SP.Ac** or the **ACCS** function has being set to **ERSY** and all alarm setpoints have been set to **OFF**. To override the remote input functions and gain access you can either place a short circuit between the appropriate remote input and ground or power up the instrument in **CAL** mode. To override the **ACCS** function you must power up in **CAL** mode.

## Using the *I NPE* display to test input level

As an aid to testing and fault finding the  or  button can be used to toggle to a percentage display which is preceded by the message **I NPE**. Note that this **I NPE** message will only be available when the instrument is powered up with the  button held in until the **CAL** message is seen (first step of **CAL** mode). The **I NPE** display will show values **0.00** to **99.99**, inputs beyond **99.99** will show as “ - - - - ”. The “ - - - - ” message indicates that the mV input is too high for the range selected. The **I NPE** display is useful when testing/fault finding since it allows the user to view the live input mV as a percentage. This allows the user to check that the change in input level is within acceptable range and that the input mV is changing by the expected amount when the load/pressure is changed. The message **I NPE** will flash momentarily once every 8 seconds whilst the percentage value is being viewed. To leave the **I NPE** display and return to normal process display requires the display to be toggled back to the normal display manually using the  or  button or for the display to be reset by removing power then powering up again.

The **RNGE** function setting determines the mV/V range for the internal analog to digital converter and hence the percentage displayed for any particular mV input. Since the A/D converter allows for approximately 20% over range on each setting an input equal to the value set at the **RNGE** setting will give a value of approximately **80.00**, the exact figure will vary between instruments due to component tolerances.

Example: **RNGE** setting = 2.5, excitation set to 10V.

For a 0mV input the **INPE** display should be approximately **0.00**.

For a 25mV input the **INPE** display should be approximately **80.00**.

For a 30mV input the **INPE** display should be approximately **99.00**.

For inputs above 30mV the **INPE** display should show “- - -”.

## 6 Calibration

Unique calibration procedures allow four different methods of calibration scaling to suit various applications. Use only one of these methods to calibrate the display.

**Method 1** - (**CAL 1/SCAL 1** etc.) - two, three, four or five calibration points are independently set from “live” inputs. The ability to set each point individually is useful where the calibration is being carried out on site and delays are experienced during the calibration procedure (e.g. filling tanks etc.). If two points are used the display will be linear. If more than two points are used the display can be made to follow a linearisation curve. The number of points to be used is set at the function. If more than two points are used it is essential that each point is at a higher input than the previous one.















**Method 2** - (**ECAL/ESCAL**) - allows entry of the mV/V figure of the load cell being used together with a scaling value i.e. no live input is required to obtain the scaling points. Note that this method is only applicable if two lineariser (**L, n PLS**) points are set.

**Method 3** - (**CAL OFFSET**) - allows a single point offset to be introduced.

**Method 4** - (**FUNC NP** set to **CAL**) - allows a simple pushbutton calibration from a live input. This method is particularly suited to item counting applications. Note that this method is only applicable if two lineariser (**L, n PLS**) points are set.

### 6.1 Method 1 - calibration by entering known live input values

Method 1 uses two, three, four or five different live input values to calibrate the instrument.

1. Enter via **CAL** mode, see page 15.
2. Check that the **dCPL** and **FRGE** functions are set as required.
3. Step through the functions until the display indicates **L, n PLS** and use the  or  pushbutton to select the number of calibration scaling points required.
4. Step through the functions until the display indicates **CAL 1**. Now press, then release, the  and  buttons simultaneously to enter the calibration functions. The display will now indicate **CAL 1** (1st calibration point) followed by a “live” reading. Apply a known input to the instrument of nominally 0% (this value is not critical and may be anywhere within the measuring range of the instrument). For example you could arrange that the load or pressure is zero at this time. When the live reading has stabilised press the  button.
5. The display will indicate **SCAL 1** (scale 1) followed by the scale value in memory. Now use the  or  button to obtain the required scale value.
6. Press the  button, the display will now indicate **CAL End** (indicating that calibration of the first point is complete).
7. The display will now indicate **CAL 2** (2nd calibration point). If you do not wish to enter the second point at this stage then press and release the  button until the **FUNC End** message is seen. If you wish to enter the second point at this stage press the  and  buttons simultaneously.
8. The display will now indicate **CAL 2** (2nd calibration point) followed by a “live” reading. Apply an input greater than that used for **CAL 1** (again this value is not critical, but there needs to be a change of at least 10% of the capacity of the load cell between points).
9. When the reading has stabilised, press the  button, the display will now read **SCAL 2** (scale 2) followed by the second scale value in memory. Use the  or  button to obtain the required scale value. Press the  button, the display will now read **CAL End** (indicating that calibration of the second point is complete).

- Repeat the process for the remaining calibration points (**CAL3** etc.). Note if more than 2 points are used it is essential that the higher points are more positive and are at least 10% of full scale higher than the previous points i.e. it is essential that the input is increasing in a positive direction. If an input is more negative than the previous calibration input an error message **BLE Err** will be seen when the calibration attempt is made.

## 6.2 Method 2 - mV/V value entry calibration

Note: this method can only be used if the **Ln Pts** function is set to **2**. This alternative calibration method allows the known mV/V value of the load cell to be entered as the calibration value. The value is entered to 3 decimal places, any number from 32.000 to -19.999 mV/V can be input. If the required value is outside this range then use a convenient available value and alter the **ESCL** value to compensate.

- Enter via **CAL** mode, see page 15.
- Check that the **dCPE** and **RNGE** functions are set as required.
- Step through the functions until the **ECAL** display is seen.
- Press the **▲** and **▼** buttons simultaneously to get a display of the current mV/V setting. Use **▲** or **▼** to alter this value to the mV/V output of the cell being used.
- Press and release the **F** button, the display will now show **ESCL** followed by the current scale value.
- Use **▲** or **▼** to alter this value if required (this value is the reading required at the maximum rated load for the cell e.g. for a 100kg load cell required to display directly in kg set the **ESCL** value to **100** (or **100.0** etc. depending on the decimal point setting).
- Press then release the **F** button the display will show **ECAL End** and the instrument moves on to the next function (**CAL OFSt**).
- Once the **ECAL** and **ESCL** values have been entered you must operate the **SEt SEt ZER0** function described below or use the **P** button or remote input **ZER0** function to zero the display with the sensor connected at no load/pressure. This zeroing process will remove the effects of any no load offset outputs present at the sensor. If using the two point calibration method (method 1), as previously described, the mV/V value is automatically calculated and may be viewed at the **ECAL** function. The **ECAL** and **ESCL** values may be recorded and re-entered to re-scale the instrument to the same load cell at a later date.

## 6.3 Method 3 - offset calibration

**CAL OFSt** - Calibration offset - the calibration offset is a single point adjustment which can be used to alter the calibration scaling values across the entire measuring range without affecting the calibration slope. This method can be used instead of performing a two point calibration when a constant measurement error is found to exist across the entire range. To perform a calibration offset press the **▲** and **▼** buttons simultaneously at the **CAL OFSt** function. A “live” reading from the input will be seen, make a note of this reading. Press the **F** button, the message **SCL** will now be seen followed by the last scale value in memory. Use the **▲** or **▼** button to adjust the scale value to the required display value for that input. For example if the “live” input reading was **50** and the required display value for this input was **70** then adjust the **SCL** value to **70**. Press the **F** button to accept changes or the **P** button to abort the scaling. If the scaling has been accepted the message **OFSt End** should be seen. If the **ZER0 RNGE Err** message is seen refer to the **ZER0 RNGE** and **CAL ZER0** functions.

## 6.4 Method 4 - remote input calibration

Note: this method can only be used if the function is set to **2**. The remote input calibration method allows simple, live input, calibration suitable for situations requiring frequent calibration such as in item counting by weight applications. In this method of calibration a remote input function (e.g. **FI NP**) is assigned to **CAL**, closure of the remote input then initiates the calibration process. The procedure is as follows:

1. Assign a remote input (e.g. via **FI NP** function) to **CAL**.
2. Assign a different remote input or the **P** button to **ZERO** and zero the display when it is in a no load condition.
3. Place a weight (or known number of items) on the weighing platform then operate the **CAL** remote input i.e. close the switch.
4. The message **SCALE** will appear on the display followed by the previous scale value in memory. Use the **▲** or **▼** button to alter this reading to the value required for this load.
5. Press then release, the **F** button, the message **CAL End** will be seen and the instrument will return to normal measure mode. Note that the **P** button may be used to abort the calibration process once beyond step 3.

## 6.5 Set zero

Used to set the load cell system to display reading of zero. Most usually used following an **ECAL** method calibration to remove any zero offset. The set zero point is entered when the load cell is installed and in a no load condition or at the load at which the display is required to read zero. To operate the set zero function press, then release, **▲** and **▼** buttons simultaneously at the **SET ZERO** function. The zero point will be retained even if power is removed and has the same effect as the remote input or **P** button **ZERO** operation.

## 6.6 Zero range function

**ZERO RANGE** - Zero Range - the zero range function allows a limit value to be set (in engineering units) above which the display will not zero i.e. if a zero operation is attempted via the **P** button, remote input or set zero function when the display value is greater than the zero range setting the display will refuse to zero and give a **ZERO RANGE Err** message (note that the **CAL OFFSET** function is also affected by the **ZERO RANGE** setting). For example if the zero range setting is **10** the instrument will only respond to a zero operation if the display reading at the time is between **-10** and **10**. If the zero range function is not required it can be set to **OFF** by pressing the **▲** and **▼** buttons simultaneously at this function. When switched off the instrument can be zeroed no matter what the display value. Note that the instrument keeps track of the value being zeroed at each operation, when the total amount zeroed from repeated operations becomes greater than the zero range value the instrument will reject the zero operation and a **ZERO RANGE Err** message will be seen. To allow a zero operation beyond this point either the **ZERO RANGE** function value will need to be raised or a new zero reference point introduced via the **CAL ZERO** function. If repeated zero operations are required the **ZERO RANGE** function should be set to **OFF** or alternatively the **SAFE** operation could be considered.

## 6.7 Zero range zero calibration function

**CAL ZERO** - Zero range zero calibration - a **CAL ZERO** zero operation can be used to ensure that the display zero and the **ZERO RANGE** reference zero are at the same point after a calibration. After a calibration the **CAL ZERO** operation can also be used to select a zero point other than the display zero



as the reference for the **ZERO RANGE** function. For example if the **CAL ZERO** operation is carried out with a display reading of **500** and a **ZERO RANGE** reading of **10** the zero range function will allow the display to zero only if the current display reading is between **490** and **510**. To perform a calibration zero press the **▲** and **▼** buttons simultaneously at the **CAL ZERO** function, a live reading will be seen, press the **⏏** button, the message **CAL ZERO End** should now be seen indicating that the instrument has accepted the zero point. Although the display reading will not change as a result of the calibration zero the input value on the display at the time of the operation will be the new zero reference point for the **ZERO RANGE** function.

## 7 Batching operation

The remote inputs **F.I.NP**, **F.I.N2** and **F.I.N3** and the **P** button function (**Pbut**) may be programmed to operate in batch (**btch**) mode. Operation of any of these inputs in batch mode will have no effect on the displayed value (i.e. the total load or weight is always visible) but can be made to affect the method in which the setpoint alarm relays and retransmission options operate.

### Alarm operation in batch mode

In addition to setting the required remote input or **P** button function to **btch** the alarm mode function for the required alarm operation mode must also be set to **btch**. The alarm operation mode functions are **A1** for alarm 1, **A2** for alarm 2 (if fitted), **A3** for alarm 3 (if fitted) etc.

When in batch mode the selected alarm may be set to operate at a given batch figure i.e. **A1Lo** or **A1Hi**, can be allocated batch values.

Example: Assume that the display is scaled to read in kilograms up to a maximum of 1000kg. **F.I.NP** is set to **btch** and **A1** is also set to **btch**. **A1Hi** is set to **100**, **A1Lo** is set to **OFF** and **A1HY** is set to **0**. If the display reading is **300** when the remote input is operated then the display will not alter but alarm 1 relay will now activate when the display reading increases by the batch value of **100** i.e. at a value of **400** or above.

The effect on alarm settings for the same example is shown in the table below.

Relay settings with <b>A1HY = 0</b>	Relay deactivates	Relay activates
<b>A1Lo = OFF, A1Hi = 100</b>	At values below <b>400</b>	At values above <b>400</b> i.e. <b>300 +</b> the batch value
<b>A1Lo = OFF, A1Hi = -100</b>	At values below <b>200</b>	At values above <b>200</b>
<b>A1Lo = 100, A1Hi = OFF</b>	At values above <b>400</b>	At values below <b>400</b>
<b>A1Lo = -100, A1Hi = OFF</b>	At values above <b>200</b>	At values below <b>200</b>
<b>A1Lo = 50, A1Hi = 100</b>	At values between <b>350</b> and <b>400</b>	At values below <b>300</b> or above <b>400</b>

The effect of a hysteresis setting (setting **A1HY** to **10** in this example) is shown in the table below.

Relay settings with <b>A1HY = 10</b>	Relay deactivates	Relay activates
<b>A1Lo = OFF, A1Hi = 100</b>	At values below <b>390</b>	At values above <b>400</b> i.e. <b>300 +</b> the batch value
<b>A1Lo = OFF, A1Hi = -100</b>	At values below <b>190</b>	At values above <b>200</b>
<b>A1Lo = 100, A1Hi = OFF</b>	At values above <b>410</b>	At values below <b>400</b>
<b>A1Lo = -100, A1Hi = OFF</b>	At values above <b>210</b>	At values below <b>200</b>

Example: Assume that **A1Hi** is set to **-25.0** and that the instrument is given a remote batch input when the display reads **200.0** i.e. the alarm relay is activated at this stage. The display does not alter when a batch input is applied but alarm 1 will not reset until the display goes below **175.0** (**200** minus **25.0**). i.e. once the batch input is applied the display value must decrease by the alarm value before the alarm will reset.

### 7.1 Retransmission operation in batch mode

As with the alarm operation the display value does not alter once the batch function has been operated. The retransmission value will, however, will be affected. Functions to set the retransmission to follow the batch operation are **FEC** or **FEC2** for analog retransmission . For serial retransmission the display must receive a request to operate its remote input function (using the “Reset special function value” command ).

## Example

The analog retransmission has been set via the `FEC_` and `FEC^` functions to transmit a 4mA signal at a display value of `0` and to transmit a 20mA signal at a display value of `1000`. The `FEC` or `FEC2` and `F:RP` functions have been set to `btch`. If the remote input is operated when the display value is `80` then the display will now transmit 4mA at a display value of `80` and will transmit 20mA at a display value of `1080`. The analog retransmission could be input to a PLC or other device for control purposes.

## 8 Serial communication

This section deals with the optional serial communications output. The required circuitry will only be fitted if the instrument was ordered with this option.

### 8.1 Serial electrical connections

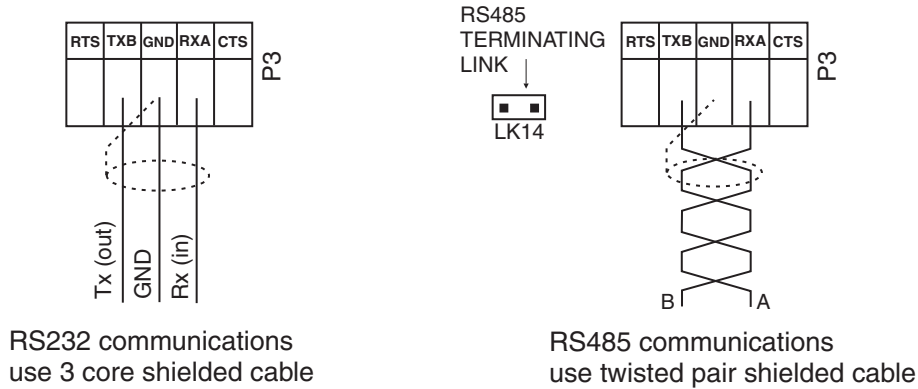

Notes: When connecting using RS232 in most cases the Tx line at the display connects to the Rx line at the device it is communicating with and the Rx line at the display connects to the Tx line at the other device, see diagram below.

The RS485 terminating link is normally only required when long cable runs are used and communication difficulties are encountered due to data reflection. If multiple instruments are connected to the same RS485 chain then set the terminating link at the first and last instrument in the chain.

Standard PC 9 pin male "D" type RS232 serial port connector.  
Rear terminals (solder side) shown.

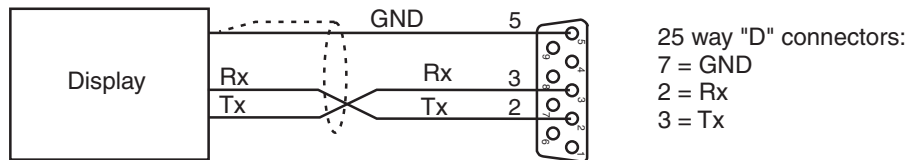

RS485 connection terminals may vary, check documentation when connecting.  
Terminal A is sometimes labeled "+" and terminal B is sometimes labeled "-"

### Serial commands

The serial commands **BAUD RATE**, **PORTY**, **OUTPUT** and **ADDR** are described below. Refer also to the **SEFL** and **SEFL TYPE** functions in the main instruction manual.

### 8.2 Baud rate for optional serial communications

Display: **BAUD RATE**  
Range: **300 . 600 . 1200 . 2400 . 4800 . 9600 . 19.2 or 38.4**  
Default Value: **9600**

Set baud rate - seen only with serial output option. Select from **300 . 600 . 1200 . 2400 . 4800 . 9600 . 19.2 or 38.4** baud.

### 8.3 Parity for optional serial communications

**Display:** *Prty*  
**Range:** *NONE*, *EVEN* or *odd*  
**Default Value:** *NONE*

Set parity - seen only with serial output option. Select parity check to either *NONE*, *EVEN* or *odd*.

### 8.4 Output mode for optional serial communications

**Display:** *Output*  
**Range:** *d: SP*, *Cont*, *POLL*, *R.buS* or *~.buS*  
**Default Value:** *Cont*

Set serial interface mode - seen only with serial output option. Allows user to select the serial interface operation as follows:

**d: SP** - sends image data from the display without conversion to ASCII.

**Cont** - sends ASCII form of display data at a rate typically 90% of the sample rate.

**POLL** - controlled by computer or PLC as host. Host sends command via RS232/485 and instrument responds as requested.

**R.buS** - is a special communications mode used with Windows compatible optional PC download software. Refer to the user manual supplied with this optional software.

**~.buS** - Modbus RTU protocol.

Refer to section 9 for detailed description of the **d: SP** and **Cont** options.

Refer to section 9.1 for detailed description of the **POLL** option.

Refer to section 10 for detailed description of the **~.buS** option.

### 8.5 Instrument address for optional serial communications

**Display:** *Addr*  
**Range:** *0* to *31*  
**Default Value:** *0*

Set unit address for polled (**POLL**) mode (*0* to *31*) - seen only with serial output option. Allows several units to operate on the same RS485 interface reporting on different areas etc. The host computer or PLC may poll each unit in turn supplying the appropriate address. The unit address ranges from 0 to 31 (DEC) but is offset by 32 (DEC) to avoid clashing with ASCII special function characters (such as <STX> and <CR>). Therefore 32 (DEC) or 20 (HEX) is address 0, 42 (DEC) or 2A (HEX) is address 10.

## 9 Serial operation

The operation mode for serial communication is set by the **Output** function, the following choices are available:

**none** - No serial communication

**d. SP** - Image display mode.

In image display mode the display value is sent via RS232/RS485 as raw data in the format <ESC> IXYYYY where:

Where: <ESC> is the ESCAPE character (27 Dec, 1B Hex)  
I is the character "I" (73 Dec, 49 Hex)  
X is the number of image bytes in ASCII (31 to 38 Hex)  
YYYY is the raw, 8 bit display data.

This information is output every display update (approx. 4 times per second - depending upon baud rate). The number of image bytes sent depends on the number of display digits present. This mode is suitable only when the receiving unit is produced by the same manufacturer as the LD. The most common usage would be to provide a large digit display for wide area viewing which just mimics the smaller display on the measuring instrument. The large digit displays automatically detect the image mode data and display the correct value accordingly. The data is in seven segment display image i.e. Bit 0 is segment A, Bit 1 is segment B etc.

**cont** - Continuous mode.

In this mode the display value is continually sent via the RS232/485 interface in ASCII format with 8 data bits + 1 stop bit. Data will be updated at approximately 90% of the display sample rate. The format for this output is: <STX> XYYYY <CR>

Where: <STX> is start of text character (2 Dec, 02 Hex)  
X SPACE (32 Dec, 20 Hex) indicates a positive value or  
X "-" (45 Dec, 2D Hex) indicates a negative value.  
YYYY is the display value in ASCII.  
<CR> is a Carriage Return (13 Dec, 0D Hex).

e.g.: If the display is showing 123456 then the instrument will send "02 31 32 33 34 35 36 0D" (HEX) to the host.

**POLL** Host controlled transmit mode, see section 9.1.

**A.buS** Special communication mode for use with optional Windows compatible software, refer to the "Download Software User Guide" booklet supplied with this optional software.

**ā.buS** Modbus RTU operation, see section 10

### 9.1 POLL mode commands

This mode requires a host computer. PLC or other device to poll the instrument to obtain display or other information or reset various setpoint parameters. Special communications software such as a terminal program is required when using **POLL** mode. Data is in ASCII format with 8 data bits + 1 stop bit. When polling the instrument it is essential that the command characters are sent with less than a 10mS delay between them. This normally means that each command line must be sent as a whole string e.g. a command such as <STX> PA <CR> is sent as one string rather than <STX> on one line followed by P etc. If testing using a "terminal" program or other software this is normally achieved by allocating a command string to a function key. Whenever the function key is operated the whole string is sent. The format used is ASCII (8 data bits + 1 stop bit) so, for instance, if address 1 is used then the string <STX> PA <CR> must be put into the terminal program as: ^BP!^M where:

^B is the ASCII character for < STX > (2 Dec, 02 Hex)  
 P is the command line to transmit the primary display value (80 Dec. 50 Hex)  
 ! is the ASCII character for address 1 (33 Dec of 21 Hex)  
 ^M is the ASCII character for < CR > (13 Dec. 0D Hex)

Typical formats for the host command is as follows:-

< ST > CA < CR > (Standard read etc.)  
 < STX > CA < CR > N < CR > XYYYYY (Set Value Command)

Where: < STX > is Start of Text Character (2 Dec, 02 Hex, ^B ASCII)  
 C is the command character (see following commands)  
 A is the unit address (Range: 32 to 63 Dec, 20 to 3F Hex, "SPACE" to ?  
 ASCII the address is offset by 32 Dec, 20 Hex)  
 < CR > is Carriage Return (13 Dec, 0D Hex, ^M ASCII)  
 N is the setpoint number in ASCII e.g.: 1 for alarm 1 etc.  
 X SPACE for positive and "-" for negative  
 YYYYY is the setpoint value in ASCII

### The POLL commands available and instrument responses are as follows:

#### Transmit primary display value: < STX > PA < CR >

e.g. ^BP!^M using a terminal program (address 1). Instructs unit to return the primary display value. The primary value is the main reading. Format of returned data is: < ACK > PAXYYYYY < CR >

Where: < ACK > is Acknowledge (6 Dec, 06 Hex)  
 P echo command received "P" (80 Dec, 50 Hex)  
 A is the responding units address (offset by 32 Dec e.g. "!" is address 1)  
 X SPACE for positive and "-" for negative  
 YYYYY is the display value in ASCII  
 < CR > is a Carriage Return (13 Dec, 0D Hex)

The number of display characters returned depends on the number of display digits present. If the decimal point is non zero then it will be sent in the appropriate place as "." (46 Dec, 2E Hex).

#### Transmit secondary display value: < STX > SA < CR >

e.g. ^BS!^M using a terminal program (address 1). Instructs unit to return the secondary display value. If no remote input function is set then the secondary value is the same as the primary value. If a remote input is set for **H**, **L**, **H, L**, **P.HLD** or **d.HLD** then the value for the selected function will be returned e.g. if set to **H, L** the high value followed by the low value will be sent (separated by a comma). Format of returned data is: < ACK > SAXYYYYY < CR >

Where: < ACK > is ASCII Acknowledge (6 Dec, 06 Hex)  
 S echo command received "S" (83 Dec, 53 Hex)  
 A is the responding units address (offset by 32 Dec e.g. "!" is address 1)  
 X SPACE for positive and "-" for negative  
 YYYYY is the display value in ASCII  
 < CR > is a Carriage Return (13 Dec, 0D Hex)

#### Reset special function value: < STX > RA < CR >

e.g. ^BR!^M using a terminal program (address 1). Instructs unit to reset remote input1 value. Will reset the stored value for Peak Hold, Valley High and Valley Low or will operate the selected special function (tare, zero, batch or preset functions only). Format of returned data is < ACK > RA < CR >

Where: < ACK > is Acknowledge (6 Dec, 06 Hex)  
 R echo command received "R" (82 Dec, 52 Hex)  
 A is the responding units address (offset by 32 Dec e.g. "!" is address 1)  
 < CR > is a Carriage Return (13 Dec, 0D Hex)

**Read low alarm setpoint:** < STX > LA < CR > N < CR >

e.g. ^BN!^M2^M to read alarm 2 low setpoint using a terminal program (address 1). Instructs unit to return the low alarm setpoint value. Format of returned data is: < ACK > LANXYYYY < CR >, where:

< ACK > is Acknowledge (6 Dec, 06 Hex)  
 L echo command received "L" (76 Dec, 4C Hex)  
 A is the responding units address (offset by 32 Dec e.g. "!" is address 1)  
 N is the relay number in ASCII  
 X SPACE for positive and "-" for negative  
 YYYY is the setpoint value in ASCII  
 < CR > is a Carriage Return (13 Dec, 0D Hex)

**Read high alarm setpoint:** < STX > HA < CR > N < CR > // e.g. ^HN!^M2^M to read alarm 2 high setpoint using a terminal program (address 1). Instructs unit to return the high alarm setpoint value. Format of returned data is: < ACK > HANXYYYY < CR >, where:

Where: < ACK > is Acknowledge (6 Dec, 06 Hex)  
 H echo command received "H" (72 Dec, 48 Hex)  
 A is the responding units address (offset by 32 Dec e.g. "!" is address 1)  
 N is the relay number in ASCII  
 X SPACE for positive and "-" for negative  
 YYYY is the setpoint value in ASCII  
 < CR > is a Carriage Return (13 Dec, 0D Hex)

**Set low alarm setpoint:** < STX > lA < CR > N < CR > XYYYYY < CR >

e.g. ^lN!^M1^M1000^ to set alarm 1 low setpoint to 1000 using a terminal program (address 1). Instructs unit to set the low alarm setpoint value.

Format of returned data is: < ACK > lANXYYYYY < CR >

Where: < ACK > is Acknowledge (6 Dec, 06 Hex)  
 l echo command received "l" (108 Dec, 6C Hex)  
 A is the responding units address (offset by 32 Dec e.g. "!" is address 1)  
 N is the relay number in ASCII  
 X SPACE for positive and "-" for negative  
 YYYY is the setpoint value in ASCII  
 < CR > is a Carriage Return (13 Dec, 0D Hex)

**Set high alarm setpoint:** < STX > hA < CR > N < CR > XYYYYY < CR >

e.g. ^hN!^M1^M5000^ to set alarm 1 low setpoint to 5000 using a terminal program (address 1). Instructs unit to set the high alarm setpoint value. Format of returned data is: < ACK > hANXYYYYY < CR > where:

Where: < ACK > is Acknowledge (6 Dec, 06 Hex)  
 h echo command received "h" (104 Dec, 68 Hex)  
 A is the responding units address (offset by 32 Dec e.g. "!" is address 1)  
 N is the relay number in ASCII  
 X SPACE for positive and "-" for negative  
 YYYY is the setpoint value in ASCII  
 < CR > is a Carriage Return (13 Dec, 0D Hex)



**Transmit instrument model and software version:** < *STX* > *IA* < *CR* > e.g. ^BI^M using a terminal program (address 1). Instructs unit to return the instrument model and software version. Format of returned data is: < *ACK* > *IACCX.X* < *CR* >

Where: < *ACK* > is Acknowledge (6 Dec, 06 Hex, ^F ASCII)  
*I* echo command received "I" (73 Dec, 49 Hex)  
*A* is the responding units address (offset by 32 Dec e.g. "!" is address 1)  
*CC* a 2 character identifier e.g. LC means loadcell input  
*X.X* is the software version number e.g. 4.6  
< *CR* > is a Carriage Return (13 Dec, 0D Hex, ^M ASCII)

**Invalid command:** If the command received from the host is invalid the unit will return the following: < *ACK* >?A < *CR* >, where:

Where: < *ACK* > is Acknowledge (6 Dec, 06 Hex, ^F ASCII)  
? echo command received "?" (63 Dec, 3F Hex)  
*A* is the responding units address (offset by 32 Dec e.g. "!" is address 1)  
< *CR* > is a Carriage Return (13 Dec, 0D Hex, ^M ASCII)

## 10 Modbus operation

When using Modbus RTU communications the instrument must be set up electrically for RS232 or RS485 communications and the **0.PULt** function must be set to **~.bus5**. The maximum recommended baud rate for Modbus operation is 9600. The following functions are available:

### Modbus Function 1 - Read coil status

Reads the ON/OFF status of the relay coils. Broadcast is not supported. Relay addresses are offset by 1 e.g. relay 1 is addressed as 0, relay 2 is addressed as 1 etc. Logic 1 = ON, Logic 0 = OFF. To read the coil status a query is sent to the instrument, the instrument then responds to the query. An example of a query to read coils 1 to 4 from the instrument at address 2 is given below.

Field name	Example(Hex)
Unit address	02
Function	01
Starting address Hi	00
Starting address Lo	00
Number of points Hi	00
Number of points Lo	04
Error check (LRC or CRC)	–

An example of a response is given below:

Field name	Example(Hex)
Unit address	02
Function	01
Byte count	01
Data (coils 4 to 1)	04
Error check (LRC or CRC)	–

The status of the relay coils is shown in the Data 04 (hex) or binary 0100. Relay 1 is indicated by the least significant binary bit. The status of the relays is therefore:

Relay 4 - OFF, Relay 3 - ON, Relay 2 - OFF, Relay 1 - OFF

### Function 3 - Read holding registers

This function reads the binary contents of the holding registers in the instrument being addressed. The value for this function is stored as a 32 bit two's complement number, 2 registers per channel are used. Note; a value of 1,000,000 represents a positive overrange and -200,000 a negative overrange. Registers 1 to 2 hold the display value, registers 3 to 4 the valley memory (lowest reading in memory), registers 5 to 6 the peak memory (highest reading in memory), registers 7 to 8 the display hold value. Registers 9 to 16 hold the alarm high values for relays 1 to 4. Note a value of 0X8000 means that the relay is set to OFF and has no high value. Registers 17 to 24 hold the alarm low values for relays 1 to 4. Note a value of 0X8000 means that the relay is set to OFF and has no low value. Register 25 represents the decimal point settings for the display. An example of a query to read holding registers 1 to 3 from the instrument at address 5 is given below.

Field name	Example(Hex)
Unit address	05
Function	03
Starting address Hi	00
Starting address Lo	00
Number of points Hi	00
Number of points Lo	03
Error check (LRC or CRC)	–

An example of a response is given below:

Field name	Example(Hex)
Unit address	05
Function	03
Byte count	06
Data Hi(register 1)	00
Data Lo(register 1)	33
Data Hi(register 2)	00
Data Lo(register 2)	25
Data Hi(register 3)	00
Data Lo(register 3)	17
Error check (LRC or CRC)	–

The contents of register 1 is 33 (hex) or 51 (decimal), register 2 is 25 (hex) or 37 (decimal), register 3 is 17(hex) or 23(decimal).

### Register table for LD displays using Modbus RTU function 3

Address	Register	Description
0X00	1	Display value high word
0X01	2	Display value low word
0X02	3	Valley memory high word
0X03	4	Valley memory low word
0X04	5	Peak memory high word
0X05	6	Peak memory low word
0X06	7	Display hold high word
0X07	8	Display hold low word
0X08	9	Relay 1 high setpoint high word
0X09	10	Relay 1 high setpoint low word
0X0A	11	Relay 2 high setpoint high word
0X0B	12	Relay 2 high setpoint low word
0X0C	13	Relay 3 high setpoint high word
0X0D	14	Relay 3 high setpoint low word
0X0E	15	Relay 4 high setpoint high word
0X0F	16	Relay 4 high setpoint low word
0X10	17	Relay 1 low setpoint high word
0X11	18	Relay 1 low setpoint low word
0X12	19	Relay 2 low setpoint high word
0X13	20	Relay 2 low setpoint low word
0X14	21	Relay 3 low setpoint high word
0X15	22	Relay 3 low setpoint low word
0X17	23	Relay 4 low setpoint high word
0X17	24	Relay 4 low setpoint low word
0X18	25	Display decimal point

## 11 Data logger

The data logger is an optional addition to the instrument. This section applies only to instruments fitted with the data logger option. If the data logger is being used with the Windows compatible software provided then refer to the separate “Download Software User Guide” booklet.

### Operation of the data logger

The data logger memory will store the hours:mins:secs, day:month and year together with the display reading at the time of log update. The log update time may be set at the **LOGUPdt** function. If an input is overranged when logged then the overrange value ( - - - ) will be logged for that channel for as long as the overrange value is present. Readings taken during power failure will not be logged. The log memory is set up in a circular format. Once the top of memory is reached the log data will overwrite the start of memory (overwriting the oldest record). The recording time available will vary depending on the memory size fitted and the update time selected. The table below shows maximum recording times.

Data is transmitted in comma separated format making it compatible with many commercially available databases/spreadsheets. Time information is downloaded in Julian time format which is again compatible with many databases/spreadsheets. The internal clock is battery backed. Downloaded log records are in the form of the time followed by the logged record for each channel at that time.

Downloaded information is transmitted via the serial output option board in RS232 or RS485 format, thus a serial output option must be fitted on all instruments with data logging software.

### Data logger Windows software

Data logger software compatible with Windows 95, 98, 2000, NT and XP is provided for use with the data logger (not tested and may not be compatible with Vista). A separate user booklet for the software is also provided. Consult this user manual for details of software setup. The data logger can also communicate using standard serial polling commands, these are listed under the heading “Serial Command Format” in this chapter.

### Datalogger table - maximum logging times (approximate)

Time between logs	32k memory days:hours	128k memory days:hours
10 seconds	0:13	2:04
20 seconds	1:02	4:08
30 seconds	1:15	6:12
1 minute	3:06	13:00
2 minutes	6:12	26:00
3 minutes	9:18	39:00
4 minutes	13:00	52:00
5 minutes	16:06	65:00
6 minutes	19:12	78:00
10 minutes	32:12	130:00
15 minutes	48:18	195:00
20 minutes	65:00	260:00
30 minutes	97:12	390:00
60 minutes	195:00	780:00

### Data logger polling functions

Usually data is downloaded using the Windows program supplied with the data logger but the data logger can be also polled via a PC etc. using the commands below. Functions which are used when the data logger option is fitted are accessible only via **CAL** mode.

**LOGUPdt** (select log update time) Displays and sets the time period between each log sample. Available selections are: **0.10** (10 seconds), **0.20** (20 seconds), **0.30** (30 seconds), **1.00** (1 minute), **2.00** (2 minutes), **3.00** (3 minutes), **4.00** (4 minutes), **5.00** (5 minutes), **6.00** (6 minutes), **10.00** (10

minutes), **15.00** (15 minutes), **20.00** (20 minutes), **30.00** (30 minutes) or **60.00** (60 minutes). Note: The data log memory (see **CLR LOG** below) must be cleared whenever the log update time is changed or the date and time is changed.

**CLR LOG** (clear data log memory) This function clears the data log memory, to clear the memory press then release **▲** and **▼** simultaneously, the display will show **CLRP** asking if you really want to clear the memory. If you wish to clear memory then press then release **▲** and **▼** simultaneously again. The log memory will then be cleared and the log period reset, the display will indicate **PROG LOG** to confirm this. Once the memory is cleared all previously logged records will be lost from the instruments memory, if the **CLRP** message is reached and it is not wished to clear the log memory then pressing and releasing either **F** or **P** will abort the function.

**SET RTC** (set time) Displays and sets the current time in hours and minutes (24 hour format HH.MM) e.g. set as **1720** for 5:20 pm.

**SET DATE** (set date) Displays and sets the current date in days and months (DD.MM format). The months will roll over automatically (up at the end of the month, down at the beginning of the month) as the day is scrolled up or down.

**SET YEAR** (set year) Displays and sets the current year (YYYY format). Valid years settings go up to 2037 (valid Julian time format years).

### Serial Command Format

Instruments using the data logger option are provided with extra software functions to the standard instrument. This section describes these extra functions.

### Initial Setup

Select the baud rate, parity and address as required. The serial output mode function (**OPUT**) must be set to **POLL** when using the data logger.

**Transmit Record Block:** <STX>DA<CR>D<CR>TTTTTTTTTT<CR>NNNN<CR>

Where: TTTTTTTTTT is the start time of the block (in Julian time format). NNNN is the number of records to be sent. Instructs the unit to send a block of logged data via the serial interface. The returned data format is: <ACK>DAD<CR> followed by NNNN records in the format:-  
TTTTTTTTTT,S1111,S2222,S3333,S4444,S5555,S6666,S7777,S8888<CR> where:

TTTTTTTTTT is the start time for each record (in Julian time format). If TTTTTTTTTT (time in "Transmit Record Block" request) is sent as 0 then the records will start at the earliest time in log memory.

S is the sign (<SPACE> for positive values and "-" for negative.)

1111, 2222 etc. are the values for each channel.

Values will only be transmitted for active channels. Invalid readings from any channel will be received as the overrange value (---) for that channel. If the start time requested is not present in the log then <ACK>DA?<CR> will be returned.

**Transmit All Logged Data:** <STX>DA<CR>A<CR>

Instructs the unit to transmit the entire data log. All log records since the last log memory reset will be sent to the host. The unit will respond with <ACK>DAA<CR> followed by all log record sent in the same format as above (Transmit Record Block)

**Transmit System Time:** <STX>DA<CR>T<CR>

Instructs the instrument to transmit the current time in Julian time format as follows:-  
<ACK>DAT TTTTTTTTTT<CR>

**Transmit the Log Start Time:** <STX>DA<CR>S<CR>

Instructs the instrument to transmit the log start time i.e. the time stamp on the first record in the log. Note that if the memory has "wrapped around", i.e. has started to overwrite existing

logged records, that the log start time will not be the original time the log started (since this time stamp and associated log record has been overwritten). The returned data format is: <ACK>DAS TTTTTTTTTT<CR>

**Transmit the Log Update Time:** <STX>DA<CR>U<CR>

Returns the current log update time as set in the log memory. The returned time may be different to the **dLAY** time if there has been no log reset since the **dLAY** function was changed. The returned data format is: <ACK>DAU NNNN<CR>, where NNNN is the update time in seconds.

**Transmit the Log Memory Size:** <STX>DA<CR>M<CR> Returns the size of the log memory in records. The returned data format is: <ACK>DAM NNNN<CR>, where NNNN is the number of records for that memory size e.g. an 8K memory will return 508.

**Set the System Time:** <STX>DA<CR>t<CR>TTTTTTTTTT<CR>

Set the instrument system clock to Julian time TTTTTTTTTT. If the command is successful then <ACK>DA<CR> will be returned. If the Julian time is invalid then <ACK>DA?<CR> will be returned.

**Set the Log Update Time:** <STX>DA<CR>u<CR>NNNN<CR>

Set the log update time to NNNN seconds. Note that the new time will not apply until a log reset is performed. If the command is successful then <ACK>DAu<CR> will be returned. If the update time is invalid then <ACK>DA?<CR> will be returned. Valid times are as shown in the **dLAY** function explanation.

**Reset the Log Memory:** <STX>DA<CR>R<CR>RESET<CR>

This command will reset the log memory. This will erase all current records and reset the log update time if it has changed. As this will result in a loss of data the command must be sent exactly as it appears or the memory will not be reset. If the command is successful then <ACK>DAR<CR> will be returned to indicate that the memory has been reset. If the command is invalid then <ACK>DA?<CR> will be returned.

## 12 Specifications

### 12.1 Technical specifications

Input:	Ratiometric 4 or 6 wire strain gauge.
Input Sensitivity:	80Ω to more than 2000Ω
Excitation:	5V, 10V or 15V, link selectable
Accuracy:	Up to 0.005% of full scale for alarms and display, depending on sample rate etc., see resolution table which follows. Accuracy for analog retransmission better than 0.05% system accuracy Using <b>ECAL</b> and <b>ESCL</b> calibration method accuracy is 1%
Sample rate:	10 to 100 sample per second, selectable. Note that output options such as serial or analog output will be updated at a slightly lower rate e.g. at 100 samples/sec. the output option will typically update at approximately 90 per second
ADC Resolution:	Up to 22 bits depending on sample rate and mV/V input, see 12.2
Display update:	Up to 4 per second, varies with <b>Filter</b> setting
Conversion Method:	Sigma delta
Microprocessor:	HC68HC11F CMOS
Ambient temperature:	LED -10 to 60° C
Humidity:	5 to 95% non condensing
Power supply:	100 and 200mm LED and 100mm electromagnetic: AC 240 or 110V selectable, 50/60Hz or AC 48/42/32/24 selectable, 50/60Hz or DC isolated wide range 12 to 24V. 38mm, 45mm or 57mm LED: AC 240 or 110V 50/60Hz or DC 12 to 48V isolated Supply type is factory configured
Output (standard):	4 x relays, Form C, rated 5A resistive. Programmable N.O. or N.C.

### Optional

Analog retransmission:	Dual channel isolated 4 to 20mA (4-20mA will drive into resistive loads of up to 800Ω)
Serial communications:	Isolated RS485 (ASCII or Modbus RTU) Non isolated RS232 or RS485 (factory configured)
Radio:	Radio transmitter and receiver for remote pushbutton setup

### 12.2 Physical characteristics

Refer to “Mechanical installation”, chapter 2 page 4 for size and weight specifications.

## Resolution table

Effective resolution (bits) for LD-WT over full scale							
Samples/sec.	mV/V input						
	0.5mV/V	1mV/V	2.5mV/V	5mV/V	10mV/V	25mV/V	50mV/V or 100mV/V
5	15.5	16.5	17.5	18.5	19.5	20.5	20.5
10	15.5	16.5	17.5	18.5	19.0	19.0	19.0
15	15.5	16.5	17.5	18.5	18.5	19.0	19.0
20	15.5	16.5	17.5	18.0	18.5	18.5	18.5
30	15.5	16.5	17.5	18.0	18.5	18.5	18.5
50	15.0	16.0	16.5	17.0	17.5	17.5	17.5
100	14.0	14.0	14.5	14.5	15.0	15.0	14.5

Note: Figures in the table above apply when the digital filter setting is 0. Add 0.5 bits effective resolution for each step on the digital filter setting e.g. if the digital filter is set at 4 add 2 bits of effective resolution to each of the figures in the table above.

Resolution in  $\mu\text{V}$  can be calculated using the resolution in bits figures above. These  $\mu\text{V}$  resolution values are calculated by the following method:

Resolution ( $\mu\text{V}$ ) = full signal input voltage range / number of divisions of resolution.

e.g. for 2.5mV/V range, 10V excitation, full signal input voltage is 2.5mV x 10V excitation = 25mV.

For 14.5 bits (100 samples/sec., zero filter) the number of divisions is  $2^{14.5}$  which equals 23170 divisions.

For 21.5 bits (5 to 30 samples/sec, filter setting of 8) the number of divisions is 2965820 ( $2^{21.5}$ ).

Resolution ( $\mu\text{V}$ ) at 14.5 bits = (2.5 mV x 10) / 23170 =  $1.08\mu\text{V}$

Resolution ( $\mu\text{V}$ ) at 21.5 bits = (2.5 mV x 10) / 2965820 =  $0.0084\mu\text{V}$



## 13 Guarantee and service

The product supplied with this manual is guaranteed against faulty workmanship for a period of 2 years from the date of dispatch.

Our obligation assumed under this guarantee is limited to the replacement of parts which, by our examination, are proved to be defective and have not been misused, carelessly handled, defaced or damaged due to incorrect installation. This guarantee is VOID where the unit has been opened, tampered with or if repairs have been made or attempted by anyone except an au authorised representative of the manufacturing company.

Products for attention under guarantee (unless otherwise agreed) must be returned to the manufacturer freight paid and, if accepted for free repair, will be returned to the customers address in Australia free of charge.

When returning the product for service or repair a full description of the fault and the mode of operation used when the product failed must be given. In any event the manufacturer has no other obligation or liability beyond replacement or repair of this product.

Modifications may be made to any existing or future models of the unit as it may deem necessary without incurring any obligation to incorporate such modifications in units previously sold or to which this guarantee may relate.

This document is the property of the instrument manufacturer and may not be reproduced in whole or part without the written consent of the manufacturer.

This product is designed and manufactured in Australia.