

8 Channel Scanning Monitor

TP488-IV accepts analog (4-20mA or 0-1VDC), AD590 or LM335 input

Ideal for

- Cool rooms, Wineries & Breweries
- Weather Stations
- Computer Rooms, Laboratories
- Remote Sites
- Tank Level Monitoring
- Air Conditioning Combined Temperature/Humidity
- Vibration Monitoring
- Pressure Monitor/Profile

Description

The TP488-IV multizone monitor provides the versatility and flexibility needed to suit applications where monitoring more than one input with relay switching outputs, and/or retransmission (optional), is required.

The TP488-IV display will cycle through the active channels showing the channel number and the value. The cycling rate can be configured via a software function.

All calibration and setting up is achieved by user pushbuttons, using easy to follow messages on the display. Programming functions include decimal point, digital filter, relay setpoint parameters, number of input channels, calibration and scaling.

The instrument accepts 0-1VDC, 4 to 20mA inputs or direct temperature inputs from LM335 or AD590 sensors. Each input may be individually calibrated and the instrument retains the calibration values in non volatile memory.

A programmable digital filter improves stability by smoothing out short term interference.

The setpoint relays may be individually configured for setpoint level, hysteresis, high and/or low alarm, relay trip delay, normally open or normally closed operation. Individual relays may be allocated to any input channel or a number of channels.

Flexible programming allows the user to select the number of inputs and outputs required. The instrument will only scan the selected active inputs.

Optional outputs include isolated analog or serial retransmission. A data logging option is available (all active channels logged) with logged data being downloaded via the serial output option.



Features

- Eight Inputs (selectable 1 to 8)
- Eight relay outputs (5 Amp, max. 240VAC)
- Measures from 4-20mA or 0-1VDC input or temperature from LM335 or AD590
- Flexible alarm functions, relays may be allocated to one or a number of channels
- Displays input in engineering units
- Auto scanning or manual display
- Programmable scan rate
- Digital filter (improves stability)
- Pushbutton calibration & setup
- Optional isolated analog retransmission with binary input channel selection
- Optional serial retransmission RS232 or RS485 (factory configured) with choice of ASCII or Modbus RTU protocols
- Optional data logging version
- Individual calibration for each input
- High Brightness 20mm LED display readable from 10m away
- Inbuilt transmitter supply
- 240, 110 VAC, isolated 12 to 48VDC or non isolated 15-24VDC operation (factory configured)
- Wallmount/Weatherproof enclosure
- Rugged IP65 construction
- 2 year guarantee



TP488-IV-3.4-0

AMALGAMATED INSTRUMENT CO PTY LTD

ACN: 001 589 439

Unit 5, 28 Leighton Place Hornsby
NSW 2077 Australia

Telephone: +61 2 9476 2244
Facsimile: +61 2 9476 2902

e-mail: sales@aicpl.com.au
Internet: www.aicpl.com.au

Specifications

Technical Specifications

Input Types:	0-1VDC, 4-20mA AD590 temperature sensor LM335 temperature sensor
Calibration Range:	0-1VDC = -1999 to 9999 4-20mA = -1999 to 9999 AD590 = -50 to 150°C LM335 = -50 to 150°C
Accuracy:	0.1% when calibrated
Sample Rate:	0.5 sec per channel (approx)
Display Scan Rate:	Programmable 0-60 sec per channel
A/D Conversion:	Dual Slope ADC
Microprocessor:	MC68HC11 CMOS
Ambient Temperature:	-10°C to 60°C
Humidity:	5 to 95% non condensing
Display:	4 digit + 1 digit (input channel) red LED, 20mm digit height
Power Supply:	AC 240 or 110V 45/65Hz DC isolated 12 to 48V or DC non-isolated 15 to 24V (factory configured)
Power Usage:	AC supply 15VA max DC supply typical 500mA (2A peak)
Outputs (standard):	8 x relays (form A) rated 5A max. 240VAC resistive Transmitter supply 12VDC regulated or 18 to 28VDC unregulated
Relay Action:	Programmable N.O. or N.C.

Output Options

Isolated Output:	4-20mA, 0-1VDC or 0-10VDC retransmission. Retransmission channel selectable via binary input lines
Isolated Output:	RS232 or RS485 serial communications. Choice of ASCII or Modbus RTU protocols (factory configured)
Isolated Output:	Data logging option with serial communications

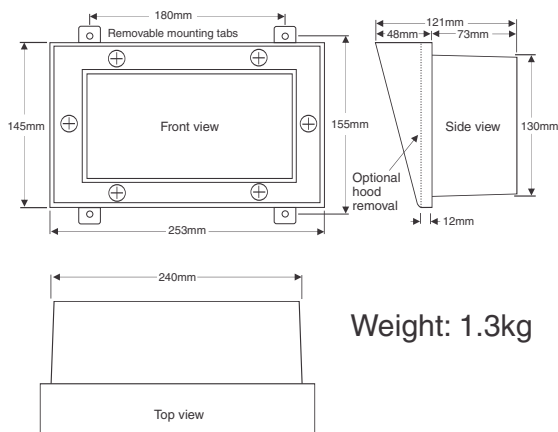

Weight: 1.3kg

Physical Characteristics

Case size:	253mm(w) x 145mm(h) x 85mm(d) to 121mm(d)
Connections:	Plug in screw terminals (maximum 2.5mm ² wire)
Weight:	1.3kg

TP488-IV Order Codes

TP488-IV - [] - []

Power Supplies

TP488-IV - [XXX] - []

240VAC	[240]
110VAC	[110]
12 to 48VDC	[DC]
15 to 24VDC non-isolated	[DCN]

Options

TP488-IV - [] - [XXX]

Analog Retransmission (4-20mA, 0-1VDC or 0-10VDC)	[A]
RS232 Serial Communications	[2]
RS485 Serial Communications	[4]
Data Logger, RS232 version 32k memory	[DL2-1]
Data Logger, RS232 version 128k memory	[DL2-2]
Data Logger, R485 version 32k memory	[DL4-1]
Data Logger, R485 version 128k memory	[DL4-2]

Panel Mounting Options

Panel Mounting Kit	LD-MTG-PM-KIT
Hood Removal	LD-HOOD-REMOVAL

