

LD4-RS
Serial Input
57mm 4 Digit
Large Digit Display
with Arithmetic Functions
Operation and Instruction Manual

Table of Contents

Introduction	3
Displaying and changing functions.	3
Mechanical Installation	4
Electrical Installation	5
AC Power supply connections	6
DC Power supply connections	6
Relay connections	7
Input/output connectors	7
Input/output links	7
Terminating resistor for RS485 communications	7
Explanation of Functions.	8
Examples	14
Function table	16
ASCII Code Conversion Listing.	18
Explanation of Functions - Arithmetic Mode.	20
Examples	23
Function Table 2 - Arithmetic Mode	24
Display Character Set	26
Specifications	27
Technical Specifications	27
Physical Characteristics	27

1 Introduction

This manual contains information for the installation and operation of the LD4-RS Monitor. The LD4-RS will accept inputs from RS232, RS485, RS422 or serial current loop inputs (factory configured). The digital display will indicate numeric and some alpha characters (when alpha function is selected). Two standard inbuilt relays are provided for alarm/control functions.

The instrument can operate as a standard serial input display or can operate in arithmetic mode. In arithmetic operation mode the instrument can be programmed to accept input from up to four RS485 or RS422 sources and combine these arithmetically. In other modes the instrument has the ability to transmit periodic polling requests of up to 8 characters in length. The time between polling requests is programmable from 0.0 to 20.0 seconds. The polling feature allows the LD4 to request data from sources which require a polling command before data can be transmitted. Unless otherwise specified at the time of order, your LD4 has been factory set to a standard configuration. Like all other LD4 series instruments the configuration and setup is easily changed by the user.

1.1 Displaying and changing functions

The LD4 series instruments are designed for high reliability in industrial applications. The high brightness LED display provides good visibility, even in areas with high ambient light levels.

The LD4-RS setup functions are configured through a push button sequence. Two levels of access are provided for setting up and calibrating:- **FUNC** (function) mode (simple push button sequence) allows access to commonly set up functions such as alarm setpoints. **CAL** mode (power up sequence plus push button sequence) allows access to all functions including calibration parameters.

The push buttons located at the top edge of the circuit board are used to alter settings. Once you have entered either **CAL** or **FUNC** mode you step through the functions by pressing and releasing the **F** push button until the required function is reached.

Entering **CAL** Mode

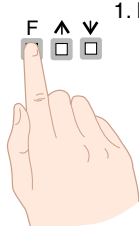

1. Remove power from the instrument and wait 5 seconds. Hold in the **F** button and reapply power. The display will indicate **CAL** as part of the "wake up messages" when the **CAL** message is seen you can release the button. Move to step 2 below.

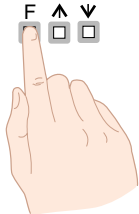

2. When the "wake up" messages have finished and the display has settled down to its normal reading press, then release the **F** button. Move to step 3 below.

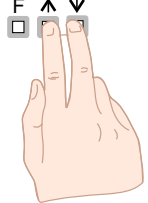

3. Within 2 seconds of releasing the **F** button press, then release the **▲** and **▼** buttons together. The display will now indicate **FUNC** followed by the first function.

Notes: If step 1 above has been completed then the instrument will remain in this **CAL** mode state until power is removed. i.e. there is no need to repeat step 1 when accessing function unless power has been removed. The instrument should show all 8's on power up e.g. **8.8.8.8**. If the instrument does not reset then these numbers will not be seen. Switch off the instrument and allow a longer time delay before powering up again.

Entering **FUNC** Mode

No special power up procedure is required to enter **FUNC** mode.

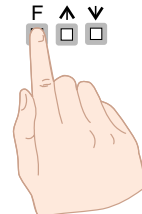

1. When the "wake up" messages have finished and the display has settled down to its normal reading press, then release the **F** button. Move to step 2 below.

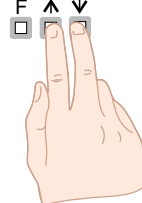

2. Within 2 seconds of releasing the **F** button press, then release the **▲** and **▼** buttons together. The display will now indicate **FUNC** followed by the first function.

2 Mechanical Installation

The instrument is designed be wall mounted. An optional panel mount kit is available for the 57mm 4 digit display, panel cut out size is 240 x 130mm. Carefully measure and drill holes, as shown below. All sizes are in mm.

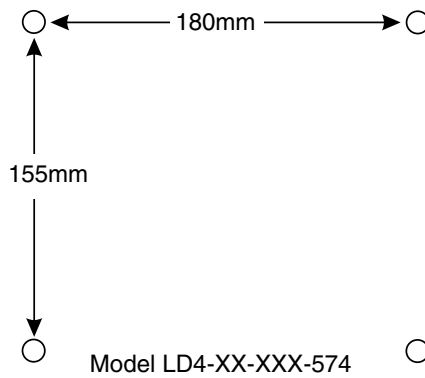
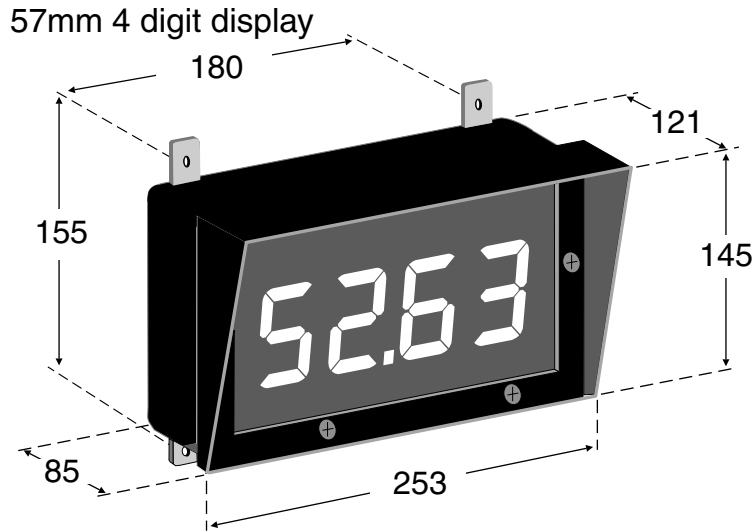

3 Electrical Installation

The LD4-RS instrument is designed for continuous operation and no power switch is fitted to the unit. It is recommended that an external switch and fuse be provided to allow the unit to be removed for servicing.

The terminal blocks, which are the plug in type for ease of installation, allow for wires of up to 1.5mm² (2.5mm² for relay and power connections) to be fitted. Connect the wires to the appropriate terminals as indicated below. Refer to other details provided in this manual to confirm proper selection of voltage, polarity and input type before applying power to the instrument. When power is applied the instrument will cycle through a display sequence, indicating the software version and other status information, this indicates that the instrument is functioning.

Use twin shielded wire for RS232 connection and twisted pair shielded wire for RS485. The RS485 cable shield should be grounded at both ends.

MAIN CIRCUIT BOARD LAYOUT (PARTIAL VIEW)

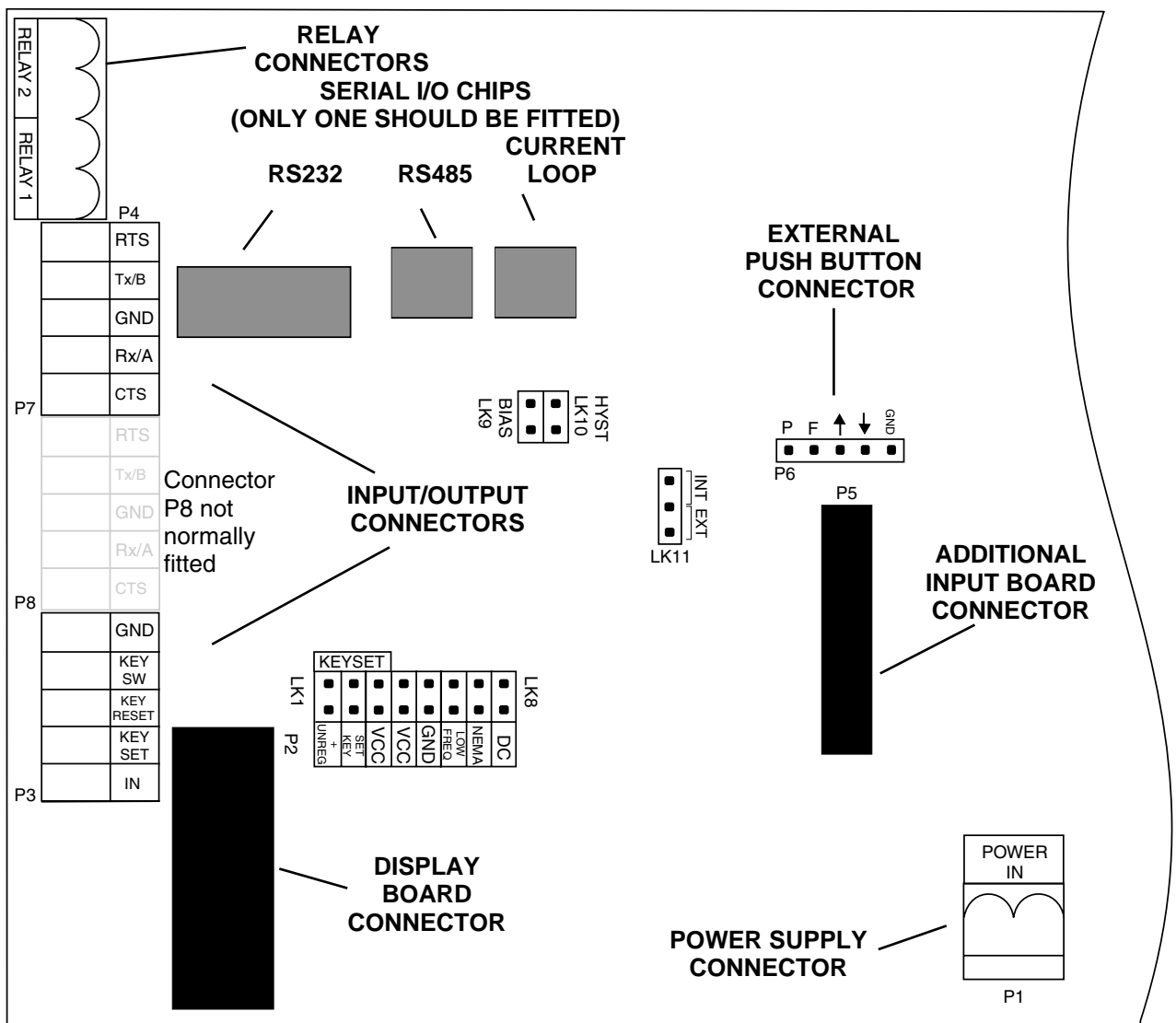

3.1 AC Power supply connections

Mains power connections (240VAC or 110VAC) are made via a plug in terminal with screw connections.

The transformer low voltage AC output goes to the power supply connector P1 on the main circuit board via the lead supplied.

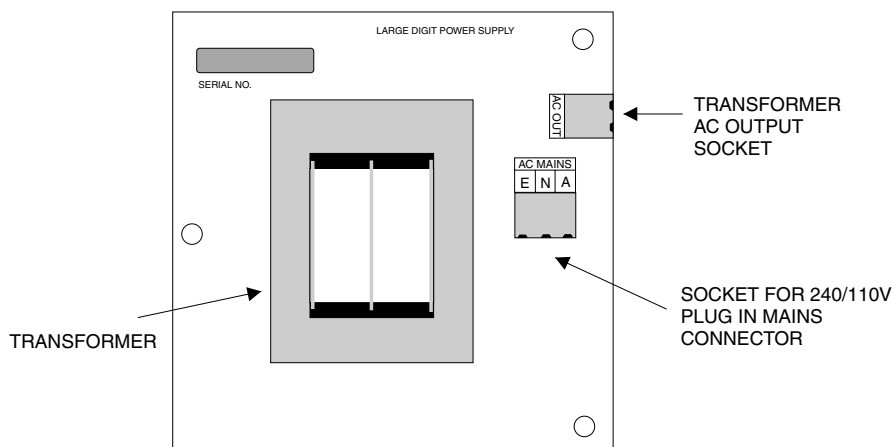

3.2 DC Power supply connections

Non isolated DC supplies (12-24VDC) may be connected directly to the main circuit board power supply connector via the plug in connector (P1) terminals. The positive and negative supply inputs may be connected either way around.

Isolated DC supplies use plug in terminals supplied on the power supply board as shown below. The output from the isolated DC supply board connects directly to the main circuit board power supply connector via the plug in connector (P1) terminals.

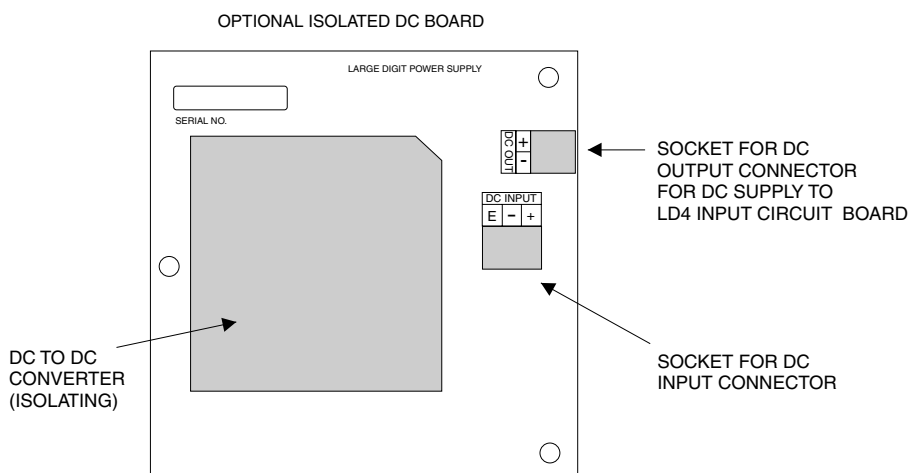

3.3 Relay connections

The LD4 is supplied with two alarm relays as standard with connections on P4. The relays are single pole, single throw types and are rated at 5A, 240VAC into a resistive load. The relay contact is voltage free and may be programmed for normally open or normally closed operation.

3.4 Input/output connectors

The diagram below shows the input/output connectors for the LD4-RS. Note: circuitry for **either** RS485 or RS232 or serial current loop will be fitted when, only the type fitted can be used.

An internal power supply allows the KEY SET input to be used to give a transmitter supply output of either 5VDC regulated or 16VDC unregulated via links LK 1 or 3. When using this output as a transmitter supply ensure that only one link (LK1 or LK3) is in and that LK2 is out. The "Set" input has no function in this instrument.

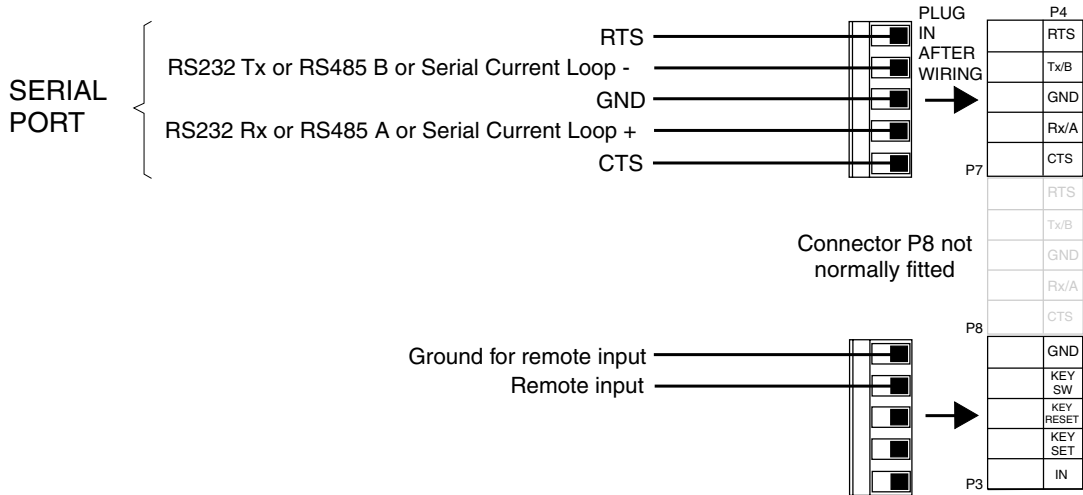

NOTE: WHEN CONNECTING USING RS232 THE Tx LINE AT THE LD4 CONNECTS TO THE Rx LINE AT THE DEVICE IT IS COMMUNICATING WITH. LIKewise THE Rx LINE AT THE LD4 CONNECTS TO Tx. WHEN USING RS485 CONNECTIONS ARE A TO A AND B TO B i.e. DO NOT CROSS THE WIRES AS YOU WOULD DO FOR RS232

3.5 Input/output links

No input/output links are required in model LD4-RS.

3.6 Terminating resistor for RS485 communications

When RS485 communications is used with long cable runs the first and last units connected on the circuit (or both units if only 2 units are connected) can be fitted with terminating resistors to help reduce the effects of signal reflections. The terminating resistor at the LD4 end is fitted externally e.g. fitted to the connector as shown below. A 100Ω resistor may be used as the terminating resistor.

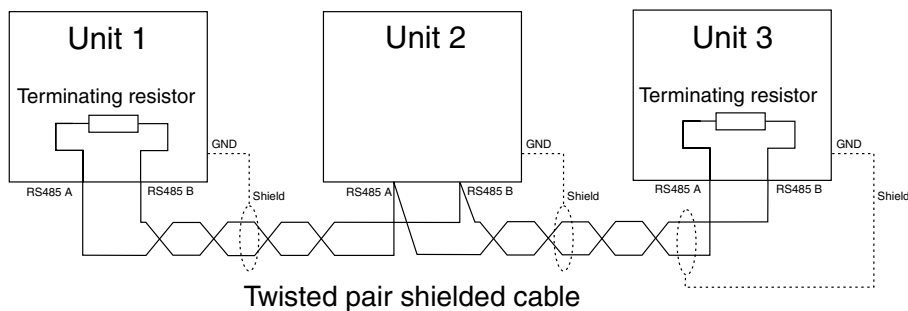

4 Explanation of Functions

Changes to functions are made by pressing the **▲** or **▼** push button when the required function is reached.

The alarm and brightness functions below are accessible via **FUNC** mode - see "Introduction" chapter.

The LD4 has an easy alarm access facility which allows access to the alarm setpoints simply by pressing the **F** button. The first setpoint will then appear and changes to this setpoint may be made to this setpoint via the **▲** or **▼** buttons. Press the **F** button to accept any changes or to move on to the next setpoint.

The instrument must be set in the manner described below to allow the easy access facility to work:

1. The alarm functions will only be seen if the **Code** function is set to **URL**.
2. The **F: NP** function must be set to **SP.AC**.
3. At least one alarm must have a setpoint, nothing will happen if all the alarm setpoints are set to **OFF**.
4. The **SP.AC** function must be set to allow access to the relays required e.g. if set to **R 1-2** then the easy access will work only with alarm relays 1 and 2 even if more relays are fitted.
5. The instrument must be in normal measure mode i.e. if the instrument is powered up so that it is in **CAL** mode then the easy access will not function. If in doubt then remove power from the instrument, wait for a few seconds then apply power again.
6. If the easy access facility is used then the only way to view or alter any other function settings is to power up via **CAL** mode i.e. there is not entry to **FUNC** mode unless the instrument is powered up in **CAL** mode.

R1Lo (alarm 1 low setpoint) - seen only when **Code** function = **URL**.

Displays and sets the alarm 1 low setpoint value. The low alarm setpoint may be disabled by pressing the **▲** and **▼** pushbuttons simultaneously. When the alarm is disabled the display will indicate **OFF**. Alarm 1 will trip when the displayed value is lower than the **R1Lo** setpoint value.

R1Hi (alarm 1 high setpoint) - seen only when **Code** function = **URL**.

Displays and sets the alarm 1 high setpoint value. The high alarm setpoint may be disabled by pressing the **▲** and **▼** pushbuttons simultaneously. When the alarm is disabled the display will indicate **OFF**. Alarm 1 will trip when the displayed value is higher than the **R1Hi** setpoint value.

R2Lo (alarm 2 low setpoint) - seen only when **Code** function = **URL**.

Displays and sets the alarm 2 low setpoint value. The low alarm setpoint may be disabled by pressing the **▲** and **▼** pushbuttons simultaneously. When the alarm is disabled the display will indicate **OFF**. Alarm 2 will trip when the displayed value is lower than the **R2Lo** setpoint value.

R2Hi (alarm 2 high setpoint) - seen only when **Code** function = **URL**.

Displays and sets the alarm 2 high setpoint value. The high alarm setpoint may be disabled by pressing the **▲** and **▼** pushbuttons simultaneously. When the alarm is disabled the display will indicate **OFF**. Alarm 2 will trip when the displayed value is higher than the **R2Hi** setpoint value.

R1Hy (alarm 1 hysteresis [deadband]) - seen only when **Code** function = **URL** and either **R1Lo** or **R1Hi** have been set to a value.

Displays and sets the alarm hysteresis limit and is common for both high and low setpoint values. The hysteresis value may be used to prevent too frequent operation of the setpoint relay when the measured value stays close to the setpoint. Without a hysteresis setting (**RxHy** set to zero) the alarm will activate when the display value goes above the alarm setpoint (for high alarm) and will reset when the display value falls below the setpoint, this can result in repeated on/off switching of the relay around the setpoint value. The hysteresis setting operates as follows:

In the high alarm mode, once the alarm is activated the input must fall below the setpoint value minus the hysteresis value to reset the alarm.

e.g. if **R1Hi** is set to **50.0** and **R1Hy** is set to **3.0** then the setpoint output relay

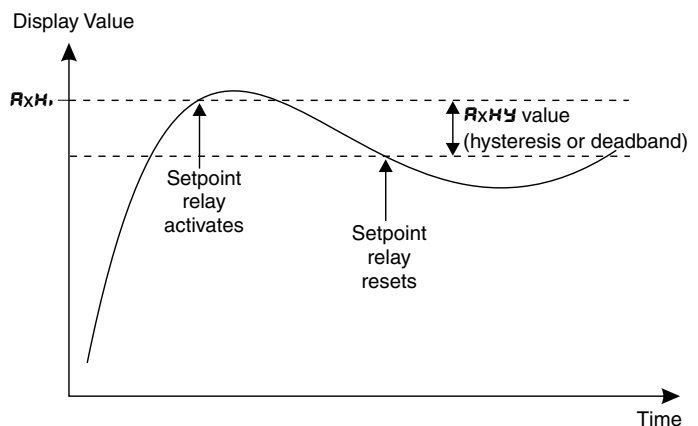

will activate once the display value goes above **50.0** and will reset when the display value goes below **47.0** (50.0 minus 3.0).

In the low alarm mode, once the alarm is activated the input must rise above the setpoint value plus the hysteresis value to reset the alarm.

e.g. if **A1Lo** is set to **20.0** and **A1H** is set to **10.0** then the alarm output relay will activate when the display value falls below **20.0** and will reset when the display value goes above **30.0** (20.0 plus 10.0).

The hysteresis units are expressed in displayed engineering units.

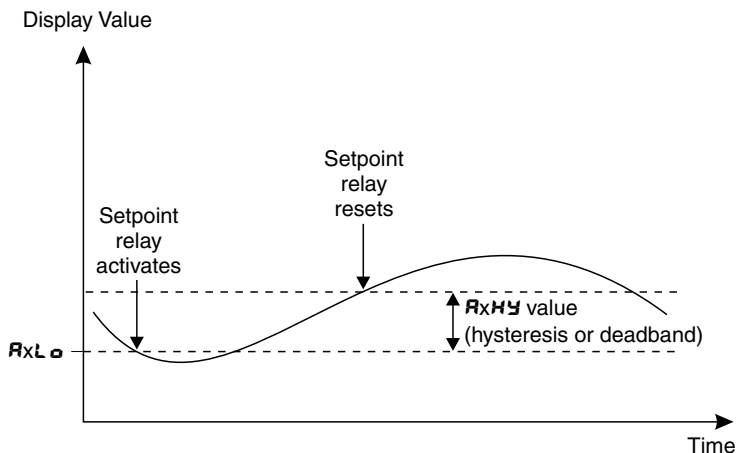

A2HY (alarm 2 hysteresis [deadband]) - seen only when **Code** function = **URL** and either **A2Lo** or **A2H** have been set to a value.

Displays and sets the alarm 2 hysteresis limit (other details as per **A1HY**).

A1t (alarm 1 trip time) - seen only when **Code** function = **URL** and either **A1Lo** or **A1H** have been set to a value.

Displays and sets the alarm 1 trip time and is common for both alarm 1 high and low setpoint values. The trip time is the delay before the alarm will trip. The alarm condition must be present continuously for the trip time period before the alarm will trip. This function is useful for preventing an alarm trip due to short non critical deviations from setpoint. The trip time is selectable over 0 to 60 seconds.

A2t (alarm 2 trip time) - seen only when **Code** function = **URL** and either **A2Lo** or **A2H** have been set to a value.

Displays and sets the alarm 2 trip time (other details as per **A1t**).

A1r (alarm 1 reset time) - seen only when **Code** function = **URL** and either **A1Lo** or **A1H** have been set to a value.

Displays and sets the alarm 1 relay reset time. With the alarm condition is removed the alarm relay will stay in its alarm condition for the time selected as the reset time. Reset time is selectable over 0 to 60 seconds.

A2r (alarm 2 reset time) - seen only when **Code** function = **URL** and either **A1Lo** or **A1H** have been set to a value.

Displays and sets the alarm 2 relay reset time. With the alarm condition is removed the alarm relay will stay in its alarm condition for the time selected as the reset time. Reset time is selectable over 0 to 60 seconds.

A1n.o or **A1n.c** (alarm 1 normally open or normally closed) - seen only when **Code** function = **URL** and either **A1Lo** or **A1H** have been set to a value.

Displays and sets the alarm relay 1 action to normally open (de-energised) or normally closed (energised), when no alarm condition is present.

A2n.o or **A2n.c** (alarm 2 normally open or normally closed) - seen only when **Code** function = **URL** and either **A1Lo** or **A1H** have been set to a value.

Displays and sets the alarm relay 2 action to normally open (de-energised) or normally closed (energised), when no alarm condition is present.

A2SP/A2t1 (relay operation independent setpoint or trailing) - seen only when **Code** function = **URL** and either **A1Lo** or **A1H** have been set to a value.

Alarm relay 2 may be programmed to operate with an independent setpoint setting or may be linked (or trailing) to operate at a fixed difference to another relay 1 setpoint. Alarm 1 (**A1**) is always independent. Select **A2SP** for an independent setting or **A2t1** for a trailing setpoint. For trailing set points, the setpoint value is entered as the difference from the alarm 1 setpoint. If the trailing setpoint is to operate ahead of alarm 1 then the value is entered as a positive number and if operating behind alarm 1 setpoint then the value is entered as a negative number. For example, with Alarm 2 set to trail alarm 1, if **A1H** is set to 1000 and **A2H** is set to 50 then Alarm 1 will trip at 1000 and alarm 2 will trip at 1050 (i.e. 1000 + 50). If Alarm 2 had been set at -50 then alarm 2 would trip at 950 (i.e. 1000 - 50).

brgt (display brightness).

Displays and sets the digital display brightness. The display brightness is selectable from **0** to **15**, where **0** = lowest intensity and **15** = highest intensity. This function is useful for reducing glare in low light environments.

dull (remote display brightness) - seen only if **F: NP** set to **dull**.



Displays and sets the level for remote input brightness switching, see **F: NP** function. When the remote input is set to **dull** the remote input can be used to switch between the display brightness level set by the **brgt** function and the display brightness set by the **dull** function. The display brightness is selectable from **0** to **15**, where **0** = lowest intensity and **15** = highest intensity. This function is useful in reducing glare when the display needs to be viewed in both light and dark ambient light levels.

The following functions can only be viewed when the instrument is powered up in **CAL** mode, see the first page of this chapter for details.

rnd (display rounding) - seen only when **Code** function = **URL**.

Displays and sets the display rounding value. This value may be set from **1-5000** displayed units (e.g. **0.00 1** to **5.000** if decimal point set to 3 places). Display rounding is useful for reducing the instrument resolution without loss of accuracy in applications where it is undesirable to display to a fine tolerance. (example: if set to **10** the instrument display will increment in multiples of 10). The display rounding will also affect the alarm setpoint settings in that the alarms will also operate on multiples of the display rounding figure.

dcp (period decimal point selection)- seen only when **Code** function = **URL**.

Displays and sets the decimal point position on the display. By pressing the  or  pushbuttons the decimal point position may be set. The display will indicate as follows: **0** (no decimal point), **0. 1** (1 decimal place), **0.02** (2 decimal places) etc. The decimal point position should be chosen to correspond to the required resolution required e.g. with **dcp** set to **0. 1** an input data string of 01.23 will be displayed as **1.2**.

fltr (digital filter) - seen only when **Code** function = **URL**.

Displays and sets the digital filter value. Digital filtering is used for reducing susceptibility to short term interference such as electrical noise, interference is normally seen as unwanted display variations from the expected value. The digital filter range is selectable from **0** to **8**, where **0** = none and **8** = most filtering. The higher the filter setting the slower the display update. A typical value for the digital filter would be **3**.

code (Select data type for display)

Two different data types or one special display mode can be selected in this function. See the “Examples” section at the end of this chapter for examples of **ASCII** and **URL** operation.

ASCII selects ASCII type input data, the input data will then be displayed without modification (see also **ALPH** function as this can also affect what is displayed). Displays of characters in **ALPH** mode are left justified.

With **URL** selected (numeric mode) the incoming characters will be converted to a numeric value, the characters will be read until a terminating character (see **chr**) is found. Once the termination character is found the numeric value will be updated and displayed. If a non numeric character is found then the conversion will cease at that point. The numeric value is filtered after conversion the **fltr** setting determines the level of filtering. Characters treated as numeric include <SPACE>, ‘+’, ‘-’, ‘.’ and numbers 0 to 9.

With **d: SP** selected (image mode) the display expects to see and input in raw data format from another instrument. This mode is generally only used when the display is connected to another AIC instrument, it is recommended that this mode is not used with any other source.

The data format expected is: <ESC>Incccc

Where: <ESC> is 27 Dec or 1B Hex

l is the ASCII character “l”

n is the number of image characters to follow

cccc are the image characters

SCM 1 (start of text character 1)

When a string is sent the instrument will look for three start of text characters, **SCM 1**, **SCM 2** and **SCM 3**. If these character do not appear, one after the other, then the string of data will not be accepted and will not be displayed. Selecting **- 1** disables the **SCM** and no matching will be required for that character. Selecting **'-2'** for means 'don't care' and any character will be taken as a match (note that a missing character will not constitute a match). Valid characters are -2 to 255 Decimal. **SCM 1** is the first start of text character.

SCM 2 (start of text character 2)

SCM 2 is the second start of text character. See **SCM 1** for details.

SCM 3 (start of text character 3)

SCM 3 is the third start of text character. See **SCM 1** for details.

TCR (terminating character)

Terminating character (may be set from **- 1** to **255**, default is **13** [carriage return <CR>]). This character is recognised as the end of transmission for a certain input stream. The next character received will be interpreted as the start of the next input stream. A setting of **- 1** means there is no terminating character.

DLRY (number of characters to skip)

Select the numbers of characters to skip before displaying (may be set from **0** to **255**, default is **0** [off]). This allows the display to skip a certain number of characters in the input stream before starting the display. This is useful for skipping control characters etc, which may be sent by the instruments along with the display information. For example if the string below is received and the **DLRY** is set to **4** then the first 4 characters in the string (1234) will be ignored and **5678** will be displayed.

<STX>12345678<CR>

BACK (number of character back)

Number of characters, back from the terminating character, to skip (set from **0** to **255**, default is **0** [off]). The display will wait for the terminating character and will then ignore the last X number of characters, depending on the value set in this function. For example if the terminating character is set to carriage return <CR> and **BACK** is set to 4 then the 4 characters 5678 will be ignored and **1234** will be displayed from the following example string:

<STX>12345678<CR>

FNCHR (number of characters from SCM)

Number of characters from the final **SCM** character - seen only when **CODE** function = **URL** or **RSC**. Normally used only when no consistent end of text character is being transmitted and operates in a similar manner to the **DLRY** function. In most circumstances the **DLRY** or **BACK** function would be used in preference to this function. If the length of the input data string is likely vary, or the position of the required display data can vary in the string, but the required data to be displayed is always a set number of bytes away from a constant character which can be used as the **SCM** character then the **FNCHR** function can be used instead of the **DLRY** function. This function sets the number of characters to be extracted from the data string immediately following the **SCM 1** (or **SCM 2** if used or **SCM 3** if used) character. If this function is not required it should be left at the default setting of **0** which will disable the function.

For example, if the string below is sent and **SCM 1** is set to **42** (* character) and **FNCHR** is set to 4 the value **5678** will be displayed since these are the 4 characters following the **SCM 1** character.

<STX>1234*56789<CR>

DPt (input string decimal point)

Normally used only in special applications using customised software when non standard arithmetic operations on the input data are required. In some systems the transmitting unit may display a decimal point position but not transmit the decimal point as part of the serial data. The **DPt** can be used to inform the LD4 display of the position of the decimal point, this information is then used in any arithmetic operations to calculate a result. The decimal point position of the result shown on the LD4 display is set via the **DPt** function. If the **DPt** function is not needed then it should be left at the default setting of **- 1** which will disable the function.

ALPH (alpha character enable)

Set this function to **OFF** to filter alpha characters from the input stream i.e. only numeric characters will be displayed and alpha characters ignored. When set to **ON** the instrument will display both alpha and

numeric characters. Note: only a limited number of alpha characters may be displayed, due to the nature of 7 segment displays, non displayable characters (e.g. W and X) will be ignored. Default setting is **OFF**.

POLL:NPt (polling function) - seen only when **Code** function = **URL** or **ASCII** .

The LD4-RS has the ability to transmit up to eight characters for polling purposes. The characters are set by functions **P.ch.1** to **P.ch.8** and the repeat rate for this polling is set by the **POLL dLAY** function. If **POLL:NPt** is set to **OFF** then no characters will be transmitted and the other polling functions will not be seen. If set to **on** then the characters selected will be transmitted at the rate selected by the **POLL dLAY** function. This ability to poll is used when the LD4-RS display is to display data from a source which requires a polling command before it will communicate. See “Examples” at the end of this chapter for polling examples.

POLL dLAY (polling delay time) - seen only when **Code** function = **URL** or **ASCII** and **POLL:NPt** function is set to **on**.

When the polling facility is being used the **POLL dLAY** function sets the repeat rate, in seconds, of the poll command. The time may be set from 0.0 seconds (continuous) to 20.0 seconds. See “Examples” at the end of this chapter for polling examples.

P.ch.1 (first poll command character) - seen only when **Code** function = **URL** or **ASCII** and **POLL:NPt** function is set to **on**.

Each of the eight poll command characters can be set from - **1** to **255** decimal. If set to - **1** then the character is ignored, if set to any other number then the equivalent ASCII character for that number will be sent (refer to section 5.1 for ASCII code conversion table). Characters **0** to **31** are special control characters such as “carriage return” and “start of text”. Use as many **P.ch** characters as required by your system and set the remaining characters to - **1** so that they are ignored. See “Examples” at the end of this chapter for polling examples.

P.ch.2 to **P.ch.8** (second, third etc. poll command characters) - see **P.ch.1** above for details.

dS.to (set the display timeout value)

This function allows the user to set a timeout value for a valid display. Valid times are 0 to 9999 seconds, a setting of 0 disables the timeout. If a new data stream is not received before the timeout value is reached then the display will be blanked.

t.out (set data timeout value)

This function allows the user to set a timeout value for the data stream. Valid times are **0.0** to **10.0** seconds, a setting of **0.0** disables the timeout. The timeout will cause the current data stream to be ignored if the time gap between characters in the stream exceeds the **t.out** value. This function helps to prevent false displays when the data stream is interrupted.

P.but (**P** button function) - applicable only when **Code** function = **URL** .

The following applies only when the **Code** function is set to **URL** . The **P** button may be set to operate some of the remote input functions. With the tare function, to prevent accidental operation, the **P** button must be held pressed for 2-3 seconds before the display will tare, momentary operation of the tare function will cause the gross value to be displayed, preceded by the message **9F05**. If both the remote input and **P** button function are operated simultaneously the **P** button will override the remote input.

The functions below are as described in the **F:NP** function above with the exception of the **P.SET** function.

Functions available are:

NONE, **H**, **L**, **H, L**, **tARE** or **2EFD**.

F:NP (remote input function) - functions marked * are applicable to **Code URL** mode only and do not work in other modes.

Terminals “GND” and “KEY SW” remote input terminals. When these terminals are short circuited, via a pushbutton or keyswitch, the instrument will perform the selected remote input function. A message will flash to indicate which function has been selected when the remote input pins are short circuited. The remote input functions are as follows:

* **NONE** - no remote function required.

* **P.HLd** - peak hold. The display will show the peak hold value whilst the remote input terminals are short circuited.

* **d.HLd** - display hold. The display will hold its value whilst the remote input terminals are short circuited

* **H** - peak memory. The peak value stored in memory will be displayed if the remote input terminals are short circuited, if the short circuit is momentary then the display will return to normal measurement after 20 seconds. If the short circuit is held for 1 to 2 seconds then the memory will be cleared.

* **L** - valley memory. The minimum value stored in memory will be displayed. Otherwise operates in the same manner as the **H** function.

* **H, L** - toggle between **H** and **L** displays. This function allows the remote input to be used to toggle between peak and valley memory displays. The first operation of the remote input will cause the peak memory value to be displayed, the next operation will give a valley memory display. **PH** or **PL** will flash before each display to give an indication of display type.

* **TARE** - tare the display. The display will be zeroed when the remote input terminals are short circuited for 2-3 seconds. Momentary operation of the remote input will cause the gross value to be displayed for a few seconds, preceded by the message **GR05**. If power is removed then the tare will be lost.

* **ZERO** - zero the display. The display will be zeroed when the remote input terminals are short circuited. The zero can be cleared via the **CLR ZERO** function, removal of power will not clear the zero.

SP.AC - setpoint access only. This blocks access to any functions except the alarm setpoint functions unless the remote input terminals are short circuited or entry is made via **CAL** mode.

NO.AC - no access. This blocks access to all functions unless the remote input terminals are short circuited or entry is made via **CAL** mode.

BULL - display brightness control. The remote input can be used to change the display brightness. When this mode is selected the display brightness can be switched, via the remote input, between the brightness level set at the **brgt** function and the brightness level set at the **BULL** function.

SPAC (setpoint access) - seen only when **Code** function = **URL**.

Sets the access to the alarm relay set points. The following choices are available:

A1 - Allows setpoint access to alarm 1 only.

A1-2 - Allows access to alarms 1 and 2. For the setpoint access function to operate the remote input function (**F: NP**) must be set to **SP.AC**.

CLR ZERO (clear zero) - seen only when **Code** function = **URL**.

Allows any zero operations performed via the **F: NP** function to be cleared. Pressing the  and  buttons simultaneously will clear the zero.

BAUDRATE (baud rate select)

Select from **300, 600, 1200, 2400, 4800, 9600, 19.2** or **38.4**.

PRTY (parity select)

Select either **NONE, EVEN** or **odd**. Default setting is **NONE**.

DATAB (number of data bits)

This function is used to inform the LD4 display of the number of data bits on the incoming data. Select from either **7.b, t** for 7 bit (plus 1 stop bit) incoming data or **8.b, t** if 8 bit (plus 1 stop bit) incoming data is used.

SER. TYPE (serial communication type)

Select the communication type to be used as either:

NONE - No serial communication

R232 - RS232 communication

R485 - RS485 communication

I 20 - 20mA serial current loop communication

Note: The communication type must match the hardware setup of the instrument e.g. if the instrument is supplied as an RS232 input display then a hardware change and a change to the **SER. TYPE** function will be required for RS485 operation. i.e. the **SER. TYPE** function on its own cannot change the communication type.

Returning to the normal measure mode

When the calibration procedure has been completed it is advisable to return the instrument to the normal mode (where calibration functions cannot be tampered with). To return to the normal mode, turn off power to the instrument, wait a few seconds and then restore power.

4.1 Examples

Following are some examples of settings for incoming data streams. See the "Function Table" chapter for an ASCII conversion table.

Example 1

Input string: <STX>Weight:+1234kg tare<CR>

Required display: **1234**

One possible group of settings to achieve the required display is:-

codE set to **URL**

tchr set to **13** (this corresponds to <CR>)

Because **URL** mode is selected the alpha characters will be ignored and the first four numeral characters before the <CR> will be displayed.

Example 2

Input string: <STX>XYZNNM1005N1200G<ETX>

Required display: **1005**

One possible group of settings to achieve the required display is:-

codE set to **URL**

dCPE set to **0.02**

bRct set to **4**

tchr set to **3** (this corresponds to <ETX>)

i.dPE set to **2**

The decimal point is set at two places and therefore appears between the two zeroes on the display. The non numeric characters are ignored since **URL** mode is used and the 1200 value is skipped because the **bRct** function is set to **4**. The decimal point appears in the correct place since **dCPE** and **i.dPE** are both set to 2 places.

Example 3

Input string: <STX>X1 ABC 12.34<CR><LF>

<STX>Y2 ABC 56.78<CR><LF>

Required display: **12.34**

One possible group of settings to achieve the required display is:-

SCH 1 set to **88** Decimal (this corresponds to X in ASCII)

SCH 2 set to **49** (this corresponds to 1 in ASCII)

SCH 3 set to **- 1** (don't care)

codE set to **URL**

dCPE set to **0.02**

i.dPE set to **2**

tchr set to **13** (this corresponds to <CR>)

The X character corresponds to **SCH 1**, the 1 character to **SCH 2**. **SCH 3** is set to don't care so only the first string is picked up. The decimal point is set at two places and the **i.dPE** function at 2 places.

Example 4 - Polling facility setup example.

The LD4-RS is connected to a different LD4 or PM4 instrument which has serial communications and is set to a polling address of 5. The LD4-RS is required to request a primary display value. The request is to be updated every 10 seconds. The polling command required for transmission of the primary display value from this LD4 is:

<STX>P5<CR>

Where: <STX> is the start of text control character, P is the primary display request character, 5 is the unit address and <CR> is the carriage return control character.

The main LD4-RS function settings required for this example are:

Code = URL

POLL NPt = on
POLL dLAY = 10.0
P.ch. 1 = 2 this correspond to <SCH>
P.ch. 2 = 80 this corresponds to P
P.ch. 3 = 37 this corresponds to address 5 (32 is address 0)
P.ch. 4 = 13 this corresponds to <CR>
P.ch. 5, P.ch. 6, P.ch. 7 and P.ch. 8 are all set to - 1

Example 5 - Polling facility setup example.

The LD4-RS is connected to a PLC via a serial link. The PLC requires a polling command of "T?" before it will transmit data to the LD4. The application requires that the PLC be polled every 2.5 seconds.

The main LD4-RS function settings required for this example are:

Code = URL (or **ASCII** depending on requirements)
POLL NPt = on
POLL dLAY = 2.5
P.ch. 1 = 84 this correspond to T
P.ch. 2 = 63 this corresponds to ?
P.ch. 3, P.ch. 4, P.ch. 5, P.ch. 6, P.ch. 7 and P.ch. 8 are all set to - 1.

5 Function table

Initial display	Meaning of display	Next display	Default Setting	Record Your Settings
# A1Lo	Alarm 1 Low Setpoint Value	Setpoint Value or OFF	OFF	
# A1Hi	Alarm 1 High Setpoint Value	Setpoint Value or OFF	1000	
# A2Lo	Alarm 2 Low Setpoint Value	Setpoint Value or OFF	OFF	
# A2Hi	Alarm 2 High Setpoint Value	Setpoint Value or OFF	1000	
# A1Hy	Alarm 1 Hysteresis	Hysteresis Value in Measured Units	1	
# A2Hy	Alarm 2 Hysteresis	Hysteresis Value in Measured Units	1	
# A1tT	Alarm 1 Trip Time	No of Seconds before Relay 1 trips	0	
# A2tT	Alarm 2 Trip Time	No of Seconds before Relay 2 trips	0	
# A1rT	Alarm 1 Reset Time	No of Seconds before Relay 2 resets	0	
# A2rT	Alarm 2 Reset Time	No of Seconds before Relay 2 resets	0	
# A1n.o or A1n.c	Alarm 1 Action N/O or N/C	A1n.o or A1n.c	A1n.o	
# A2n.o or A2n.c	Alarm 2 Action N/O or N/C	A2n.o or A2n.c	A2n.o	
# A2SP or A2t!	Alarm 2 trailing or setpoint mode	A2SP or A2t!	A2t!	
br9t	Display Brightness	1 to 15	15	
duLL	Remote Brightness Control	0 to 15	0	
Functions which follow are accessible only via EARL mode				
# drnd	Display Rounding	Value in memory	1	
# dCPt	Decimal Point	Auto 0.0, 1.0, 0.02 or 0.003	Auto	
# FLtr	Digital Filter	0 to 8	3	
codE	Select data type for display	ASCi , URL , d! SP or AFtH	d! SP	
^ SCH1	Start of text character 1	value in memory	- 1	
^ SCH2	Start of text character 2	value in memory	- 1	
^ SCH3	Start of text character 3	value in memory	- 1	

^ tchr	Terminating Character	- 1 to 255	13	
^ dLAY	No. of characters to Skip	0 to 255	0	
^ bAct	No. of characters Back	0 to 24	0	
^ n.Chr	No. of characters to skip from SCM 1	0 to 10	0	
^ i.dpE	Decimal point position of incoming data	- 1 to 8	- 1	
^ ALPH	Alpha Characters On or Off	on or OFF	OFF	
^ POLL i nPE	Polling	on or OFF	OFF	
^ POLL dLAY	Poll delay	0.0 to 20.0	1.0	
^ P.ch. 1	1st poll character	- 1 to 255	- 1	
^ P.ch. 2	2nd poll character	- 1 to 255	- 1	
^ P.ch. 3	3rd poll character	- 1 to 255	- 1	
^ P.ch. 4	4th poll character	- 1 to 255	- 1	
^ P.ch. 5	5th poll character	- 1 to 255	- 1	
^ P.ch. 6	6th poll character	- 1 to 255	- 1	
^ P.ch. 7	7th poll character	- 1 to 255	- 1	
^ P.ch. 8	8th poll character	- 1 to 255	- 1	
dS.to	Display timeout secs.	0 to 9999	10	
t.out	Data timeout secs.	1.0 to 10.0	1.0	
P.but	 Button Function	NONE, H, Lo, H, Lo, tARFE or 2EFO	NONE	
r.i nP	Remote Input Function	NONE, P.HLd, d.HLd, H, Lo, H, Lo, tARFE, 2EFO, SP.AC, No.AC or dULL	NONE	
# ACCS	Alarm relay access mode	OFF, EASY or NONE	OFF	
# SPAC	Alarm relay setpoint access	A 1 or A 1-2	A 1	
# CLR 2EFO	Clear Zero	CLrd	n/a	
bAudRate	Baud Rate Select	300, 600, 1200, 2400, 4800, 9600, 19.2 or 38.4	9600	
Prty	Parity Select	none, EVEN or odd	NONE	
dAtA	Number of data bits	7.b, t or 8.b, t	8.b, t	
SEF. 1	Serial Input Type	NONE, r232, r485 or i 20	r232	

Notes:

Functions shown # are accessible only when **codE** set to **URL** or **RFtH**.

Functions show ^ are accessible only when **codE** set to **URL**, **RSC** or **RFtH**.

5.1 ASCII Code Conversion Listing

ASCII for control characters is shown in brackets. e.g. STX is entered as ^B if typing into a communications package for computer communication to the LD4-RS. For example <STX>1234<CR> would be typed in as:

^B1234^M

ASCII Char.	Dec	Hex	ASCII Char.	Dec	Hex
NUL (^@)	000	00	SP ()	032	20
SOH (^A)	001	01	!	033	21
STX (^B)	002	02	“	034	22
ETX (^C)	003	03	#	035	23
EOT (^D)	004	04	\$	036	24
ENQ (^E)	005	05	%	037	25
ACK (^F)	006	06	&	038	26
BEL (^G)	007	07	‘	039	27
BS (^H)	008	08	(040	28
HT (^I)	009	09)	041	29
LF (^J)	010	0A	*	042	2A
VT (^K)	011	0B	+	043	2B
FF (^L)	012	0C	,	044	2C
CR (^M)	013	0D	-	045	2D
SO (^N)	014	0E	.	046	2E
SI (^O)	015	0F	/	047	2F
DLE (^P)	016	10	0	048	30
DC1 (^Q)	017	11	1	049	31
DC2 (^R)	018	12	2	050	32
DC3 (^S)	019	13	3	051	33
DC4 (^T)	020	14	4	052	34
NAK (^U)	021	15	5	053	35
SYN (^V)	022	16	6	054	36
ETB (^W)	023	17	7	055	37
CAN (^X)	024	18	8	056	38
EM (^Y)	025	19	9	057	39
SUB (^Z)	026	1A	:	058	3A
ESC (^[)	027	1B	;	059	3B
FS (^\\)	028	1C	<	060	3C
GS (^])	029	1D	=	061	3D
RS (^_)	030	1E	>	062	3E
US (^_)	031	1F	?	063	3F
@	064	40	‘	096	60

CONTINUED

ASCII Char.	Dec	Hex	ASCII Char.	Dec	Hex
A	065	41	a	097	61
B	066	42	b	098	62
C	067	43	c	099	63
D	068	44	d	100	64
E	069	45	e	101	65
F	070	46	f	102	66
G	071	47	g	103	67
H	072	48	h	104	68
I	073	49	i	105	69
J	074	4A	j	106	6A
K	075	4B	k	107	6B
L	076	4C	l	108	6C
M	077	4D	m	109	6D
N	078	4E	n	110	6E
O	079	4F	o	111	6F
P	080	50	p	112	70
Q	081	51	q	113	71
R	082	52	r	114	72
S	083	53	s	115	73
T	084	54	t	116	74
U	085	55	u	117	75
V	086	56	v	118	76
W	087	57	w	119	77
X	088	58	x	120	78
Y	089	59	y	121	79
Z	090	5A	z	122	7A
[091	5B	{	123	7B
\	092	5C		124	7C
]	093	5D	}	125	7D
^	094	5E	~	126	7E
_	095	5F	DEL	127	7F

6 Explanation of Functions - Arithmetic Mode

This second explanation of functions chapter deals with the LD4-RS panel meter operation when the **Code** function is set to **Arth**. i.e. when up to four inputs are present via an addressed RS458 connection and these inputs are to be combined via an arithmetic formula.

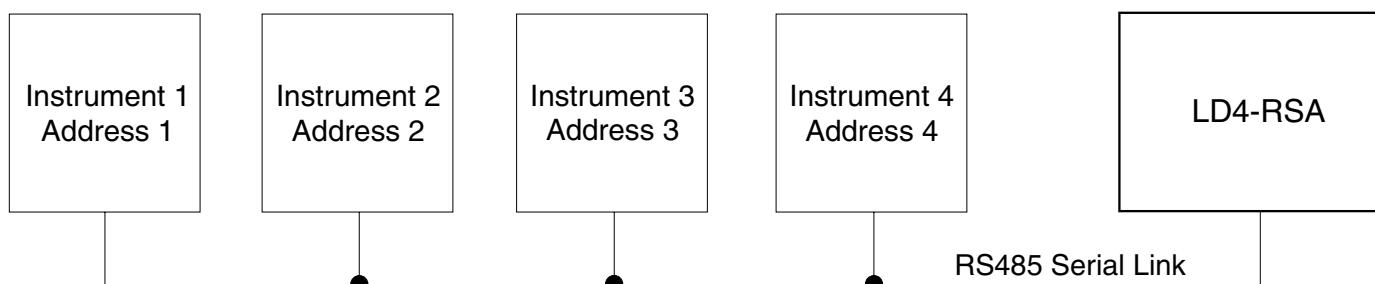

In **Arth** mode the LD4-RS will automatically scan the number of input channels selected by the **ArthCh** function (up to 4 channels). These can then be combined by introducing scaling factors to each channel (**R1.b1.C1** etc.) and by performing an arithmetic function between channels (**Add.Prod** etc.). See the formula under **ER1** function and also refer to the examples at the end of this chapter.

Many **Arth** mode functions are shared with other modes. Functions specific to **Arth** mode are dealt with in this chapter. Refer to Chapter 5 for explanation of the functions common to other modes listed below:

R1Lo, R1Hi, R2Lo, R2Hi, R1Hy, R2Hy, Rin.o/Rin.c, R2n.o/R2n.c, R2SP/R2t1, br9t, dULL, FECL, FECL, drnd, dCPL, FLtr, bAudFAte, PrtY, dAteR, code, dS.to, t.out, P.out, F.I NP and **SPAC**.

The following functions will only be seen when the **code** function is set to **Arth**.

ArthCh (number of channels)

Displays and selects the number of input channels used. Select between 1 and 4 channels. The LD4-RS will automatically poll the number of channels selected. Each input channel must be set to a different address. Addresses which can be used are 1, 2, 3 or 4. e.g. if only 2 channels are used then these must be given addresses 1 and 2. The addresses are set within the transmitting instrument, not in the LD4-RS. The addresses referred to in the LD4-RS instructions relates to the information required from each input channel and the address of that channel.

The following display messages are not shown for unused channels. e.g. the **Ch3Addr** function will not be seen if only 2 channels are selected.

Ch1Addr (data required from channel 1 input)

This function determines what information is requested for the channel 1 input. It also determines which address the information is taken from.

Choices are **P1, P2, P3, P4, S1, S2, S3** or **S4**. The letters **P** and **S** refer to the primary (**P**) or secondary (**S**) display values from the transmitting instrument e.g. the primary display value of a pH instrument will be the pH value on the display whilst the secondary display value would be the solution temperature. The number refers to the address of the instrument. For example if **Ch1Addr** function has **P3** selected then the primary display value from the instrument with address 3 will be requested as the channel 1 input for the LD4-RS. This value will then be placed in the formula below as the **Ch1** value.

Ch2Addr (data required from channel 2 input)

This function determines what information is requested for the channel 2 input i.e. the **Ch2** value to be input to the formula. Other details are as per **Ch1Addr** function.

Ch3Addr (data required from channel 3 input)

This function determines what information is requested for the channel 3 input i.e. the **Ch3** value to be input to the formula. Other details are as per **Ch1Addr** function.

Ch4Addr (data required from channel 4 input)

This function determines what information is requested for the channel 4 input i.e. the **Ch4** value to be input to the formula. Other details are as per **Ch1Addr** function.

OP 2 ([result of channel 1 and 2] and channel 3)

Add result of (Ch1 **OP 1** Ch2) plus Ch3
Sub result of (Ch1 **OP 1** Ch2) minus Ch3
Prod result of (Ch1 **OP 1** Ch2) times Ch3
Div result of (Ch1 **OP 1** Ch2) divided by Ch3
High highest of result of (Ch1 **OP 1** Ch2) or 3
Low lowest of result of (Ch1 **OP 1** Ch2) or 3
SINE result of (Ch1 **OP 1** Ch2) times the sine of the angle displayed at channel 3
COS result of (Ch1 **OP 1** Ch2) times the cosine of the angle displayed at channel 3
C.Sub channel 1 clock input minus channel 2 clock input

OP 3 ([[result of channel 1 and 2] and channel 3) and channel 4)

Add result of (Ch1 **OP 1** Ch2 **OP 2** Ch3) plus Ch4
Sub result of (Ch1 **OP 1** Ch2 **OP 2** Ch3) minus Ch4
Prod result of (Ch1 **OP 1** Ch2 **OP 2** Ch3) times Ch4
Div result of (Ch1 **OP 1** Ch2 **OP 2** Ch3) divided by Ch4
High highest of result of (Ch1 **OP 1** Ch2 **OP 2** Ch3) or 4
Low lowest of result of (Ch1 **OP 1** Ch2 **OP 2** Ch3) or 4
SINE result of (Ch1 **OP 1** Ch2 **OP 2** Ch3) times the sine of the angle displayed at channel 4
COS result of (Ch1 **OP 1** Ch2 **OP 2** Ch3) times the cosine of the angle displayed at channel 4
C.Sub channel 1 clock input minus channel 2 clock input

Ch 0 (display polarity - channel 0)

Displays and sets the polarity selection for the display of the engineering value for channel 0. Channel 0 is the channel which displays the result of the arithmetic operations. If set to **BOTH** then the display will indicate both positive and negative values. If set to **POS** the display will allow only positive values with any values below zero being rounded to zero. If set to **NEG** then the display will allow only negative values with any value above zero being rounded to zero. If set to **ABS** then the absolute value will be displayed i.e. negative numbers will be displayed as positive numbers.

Ch 1 (display polarity - channel 1)

As per **Ch 0** but applies to channel 1 i.e. **BOTH** - allows positive and negative values for channel 1, **POS** - allows only positive values, **NEG** - allows only negative values, **ABS** gives the absolute value.

Ch 2 (display polarity - channel 2)

As per **Ch 0** but applies to channel 2 i.e. **BOTH** - allows positive and negative values for channel 2, **POS** - allows only positive values, **NEG** - allows only negative values, **ABS** gives the absolute value.

Ch 3 (display polarity - channel 3)

As per **Ch 0** but applies to channel 3 i.e. **BOTH** - allows positive and negative values for channel 3, **POS** - allows only positive values, **NEG** - allows only negative values, **ABS** gives the absolute value.

Returning to the normal measure mode

When the calibration procedure has been completed it is advisable to return the instrument to the normal mode (where calibration functions cannot be tampered with). To return to the normal mode, turn off power to the instrument, wait a few seconds and then restore power.

6.1 Examples

The following examples may be used as a guide for setting up your instrument.

Example 1:

To get an average of channels 1, 2, 3 and 4 each input is added together and divided by 4:

$$\dots \left(\frac{Ch1}{4} + \frac{Ch2}{4} + \frac{Ch3}{4} + \frac{Ch4}{4} \right)$$

```

Program . . . . ER1=1.Eb1=0.EC1=4.
..... ER2=1.Eb2=0.EC2=4.
..... ER3=1.Eb3=0.EC3=4.
..... ER4=1.Eb4=0.EC4=4.
..... OP1=Add
..... OP2=Add
..... OP3=Add
  
```

$$\frac{1 \times (Ch1+0)}{4} \text{ Add } \frac{1 \times (Ch2+0)}{4} \text{ Add } \frac{1 \times (Ch3+0)}{4} \text{ Add } \frac{1 \times (Ch4+0)}{4}$$

Example 2: Three inputs are present. The display is to indicate the highest of the 3 inputs. Channel 1 input is to be multiplied 2/3.

```

Program . . . . ER1=2.Eb1=0.EC1=3.
..... ER2=1.Eb2=0.EC2=1.
..... ER3=1.Eb3=0.EC3=1.
..... OP1=H, 9H
..... OP2=H, 9H
  
```

$$\frac{2 \times (Ch1+0)}{3} \text{ HiGH } \frac{1 \times (Ch2+0)}{1} \text{ HiGH } \frac{1 \times (Ch3+0)}{1}$$

Example 3: To multiply the figure displayed on channel 1 by the sine of the angle of the figure displayed on channel 2. The second channel would normally be scaled from 0 to 360 when either the sine or cosine is being used, however numbers outside this range are acceptable.

```

Program: . . . . ER1=1.Eb1=0.EC1=1.
..... ER2=1.Eb2=0.EC2=1.
..... OP1=SINE.
  
```

$$\frac{1 \times (Ch1+0)}{1} \text{ SINE } \frac{1 \times (Ch2+0)}{1}$$

7 Function Table 2 - Arithmetic Mode

Initial display	Meaning of display	Next display	Default settings	Record Your Settings
A 1Lo	Alarm 1 Low Setpoint Value	Setpoint Value or OFF	OFF	
A 1H	Alarm 1 High Setpoint Value	Setpoint Value or OFF	1000	
A 2Lo	Alarm 2 Low Setpoint Value	Setpoint Value or OFF	OFF	
A 2H	Alarm 2 High Setpoint Value	Setpoint Value or OFF	1000	
A 1HY	Alarm 1 Hysteresis	Hysteresis Value in Measured Units	1	
A 2HY	Alarm 2 Hysteresis	Hysteresis Value in Measured Units	1	
A 1t	Alarm 1 Trip Time	No of Seconds before Relay 1 trips	0	
A 2t	Alarm 2 Trip Time	No of Seconds before Relay 2 trips	0	
A 1r	Alarm 1 Reset Time	No of Seconds before Relay 2 resets	0	
A 2r	Alarm 2 Reset Time	No of Seconds before Relay 2 resets	0	
A 1n.o or A 1n.c	Alarm 1 Action N/O or N/C	A 1n.o or A 1n.c	A 1n.o	
A 2n.o or A 2n.c	Alarm 2 Action N/O or N/C	A 2n.o or A 2n.c	A 2n.o	
A 2SP or A 2t!	Alarm 2 trailing or setpoint mode	A 2SP or A 2t!	A 2t!	
b r g t	Display brightness	0 to 15 (15 = max brightness)	15	
d U L L	Remote brightness control	0 to 15	0	
Functions below are accessible only via CAL mode				
r E C -	Retransmission low level. Seen only if option fitted.	Value in memory	0	
r E C ^	Recorder output high limit. Seen only if option fitted.	Value in memory	1000	
d r n d	Display rounding	Value in memory	1	
d C P t	Display decimal point	Decimal point (i.e. 0.1 or 0.02 etc.)	0	
F L t r	Digital filter	0 to 8 (8 = max filtering)	2	
A r t h C H	Number of channels	1, 2, 3 or 4	4	
C h 1 A d d r	Channel 1 address	P 1, P 2, P 3, P 4, S 1, S 2, S 3 or S 4	P 1	
C h 2 A d d r	Channel 2 address	P 1, P 2, P 3, P 4, S 1, S 2, S 3 or S 4	P 2	
C h 3 A d d r	Channel 3 address	P 1, P 2, P 3, P 4, S 1, S 2, S 3 or S 4	P 3	
C h 4 A d d r	Channel 4 address	P 1, P 2, P 3, P 4, S 1, S 2, S 3 or S 4	P 4	
C h 1 d C P t	Channel 1 decimal point	Decimal point (e.g. 0.1 or 0.02 etc.)	0	
C h 2 d C P t	Channel 2 decimal point	Decimal point (e.g. 0.1 or 0.02 etc.)	0	

Ch3 dCPE	Channel 3 decimal point	Decimal point (e.g. 0. for 0.02 etc.)	0	
Ch4 dCPE	Channel 4 decimal point	Decimal point (e.g. 0. for 0.02 etc.)	0	
EA1	Channel 1 A function	Value in memory	1	
Eb1	Channel 1 b function	Value in memory	0	
EC1	Channel 1 C function	Value in memory	1	
EA2	Channel 2 A function	Value in memory	1	
Eb2	Channel 2 b function	Value in memory	0	
EC2	Channel 2 C function	Value in memory	1	
EA3	Channel 3 A function	Value in memory	1	
Eb3	Channel 3 b function	Value in memory	0	
EC3	Channel 3 C function	Value in memory	1	
EA3	Channel 3 A function	Value in memory	1	
Eb3	Channel 3 b function	Value in memory	0	
EC3	Channel 3 C function	Value in memory	1	
OP1	Operation 1	Add.Sub.Prod.d.u. H, 9h.Lo SI: NECOS or C.SUB	Add	
OP2	Operation 2	Add.Sub.Prod.d.u. H, 9h.Lo SI: NECOS or C.SUB	Add	
OP3	Operation 3	Add.Sub.Prod.d.u. H, 9h.Lo SI: NECOS or C.SUB	Add	
Ch1	Display polarity, channel 1	b0tH, POS or NEG	both	
Ch2	Display polarity, channel 2	b0tH, POS or NEG	both	
Ch3	Display polarity, channel 3	b0tH, POS or NEG	both	
Ch4	Display polarity, channel 4	b0tH, POS or NEG	both	
code	Select data type for display	d: SP, ASCII, UAL or AFtH	d: SP	
dS.to	Display time out (seconds)	Value in memory	10.0	
t.out	Time out (seconds)	Value in memory	1.0	
P.but	P button function	NONE, H, Lo, H, Lo, tARF or 2EFO	NONE	
r: NP	Remote input function	NONE, P, HLD, d, HLD, H, Lo, H, Lo, tARF, 2EFO, SP, AC, No, Ac or dULL	NONE	
ACCS	Alarm relay access mode	OFF, EASY or NONE	OFF	
SPAC	Setpoint access	A1 or A1-2	A1	
CLr 2EFO	Clear Zero	CLrd	n/a	
BAUD RATE	Baud rate select	50, 75, 150, 300, 600, 1200, 2400, 4800, 9600 or 19.2	9600	
Prty	Parity select	NONE, EVEN or odd	NONE	
dARtA	Data type	B, b, t or 7, b, t	B, b, t	
SEt. tYPE	Serial communication type	r232 or r485	r232	

8 Display Character Set

Some alphabetic characters cannot be displayed in seven segment format, listed below are the input character and the resultant display. If an alphabetic character is received which can be displayed on the seven segment display it is displayed, and the input is advanced by one. If the character is not displayable (e.g. W), then the character is ignored. See the "Function table" chapter for a full ASCII conversion chart.

ASC11 Char- acter	Dec	Hex	Digital Display	ASC11 Char- acter	Dec	Hex	Digital Display
SPACE	032	20	-	U	085	55	U
-	045	21	.	V	086	56	U
.	046	22		W	NOT	DISPLAYABLE	
0	048	30	0	X	NOT	DISPLAYABLE	
1	049	31	1	Y	089	59	Y
2	050	32	2	Z	090	5A	2
3	051	33	3	a	097	61	A
4	052	34	4	b	098	62	b
5	053	35	5	c	099	63	c
6	054	36	6	d	100	64	d
7	055	37	7	e	101	65	E
8	056	38	8	f	102	66	F
9	057	39	9	g	103	67	9
A	065	41	A	h	104	68	h
B	066	42	B	i	105	69	,
C	067	43	C	j	106	6A	J
D	068	44	D	k	NOT	DISPLAYABLE	
E	069	45	E	l	108	6C	l
F	070	46	F	m	NOT	DISPLAYABLE	
G	071	47	G	n	110	6E	n
H	072	48	H	o	111	6F	o
I	073	49	I	p	112	70	P
J	074	4A	J	q	113	71	q
K	NOT	DISPLAYABLE		r	114	72	r
L	076	4C	L	s	115	73	S
M	NOT	DISPLAYABLE		t	116	74	t
N	078	4E	N	u	117	75	u
O	079	4F	O	v	118	76	v
P	080	50	P	w	NOT	DISPLAYABLE	
Q	081	51	Q	x	NOT	DISPLAYABLE	
R	082	52	R	y	121	79	Y
S	083	53	S	z	122	7A	Z
T	084	54	T				

9 Specifications

9.1 Technical Specifications

Input types:	Either RS232, RS485 or Serial current loop (input type is factory configured)
Baud rate:	300, 600, 1200, 2400, 4800, 9600, 19200 or 38400 Programmable
Microprocessor:	MC68HC11 CMOS
Ambient Temperature:	-10 to 60°C,
Humidity:	5 to 95% non condensing
Power Supply:	AC 240V, 110V 50/60Hz or DC 15 to 24V non isolated or DC 12V, 24V or 48V isolated Supply type is factory configured
Outputs:	2 x Setpoint relays, form A, rated 5A at 240VAC
Power Consumption:	AC supply 15 VA max, DC supply, consult supplier (depends on voltage and options)

9.2 Physical Characteristics

Model LD4-X-X-574	Case size (mm) = 255 x 145 x 125 Weight: = 1.3 kg Mounting hole locations (mm) = 180(w) x 155(h)
-------------------	--

10 Guarantee and Service

The product supplied with this manual is guaranteed against faulty workmanship for a period of 2 years from the date of dispatch.

Our obligation assumed under this guarantee is limited to the replacement of parts which, by our examination, are proved to be defective and have not been misused, carelessly handled, defaced or damaged due to incorrect installation. This guarantee is VOID where the unit has been opened, tampered with or if repairs have been made or attempted by anyone except an authorised representative of the manufacturing company.

Products for attention under guarantee (unless otherwise agreed) **must be returned to the manufacturer freight paid** and, if accepted for free repair, will be returned to the customers address in Australia free of charge.

When returning the product for service or repair a full description of the fault and the mode of operation used when the product failed must be given.

In any event the manufacturer has no other obligation or liability beyond replacement or repair of this product.

Modifications may be made to any existing or future models of the unit as it may deem necessary without incurring any obligation to incorporate such modifications in units previously sold or to which this guarantee may relate.

**This document is the property of
the instrument manufacturer
and may not be reproduced in whole or part without the
written consent of the manufacturer.**

This product is designed and manufactured in Australia.

